



AHEAD OF WHAT'S POSSIBLE™

电源模块 设计与挑战

Lorry Liang

Asia Power Systems Engineering Director





微型电源模块的需求来源



21电源网
21dianyuan.com



电源设计的三个挑战



Performance 3 Key Metrics

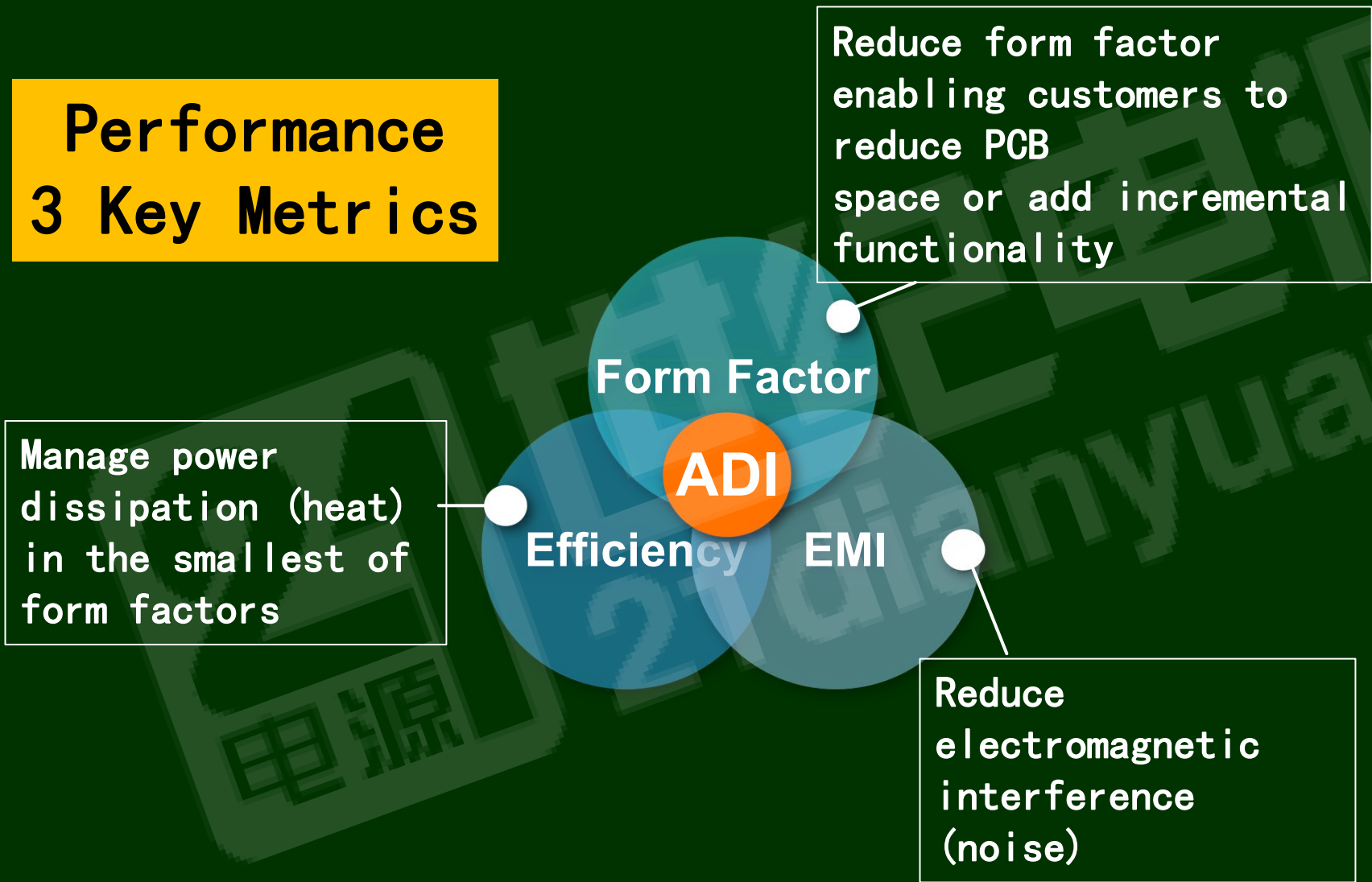



电源设计，到底是简单还是复杂

Design requirement 5V to 3.3V @ 2A

▶ Input voltage range

- V_{MAX}
- V_{NOM}
- V_{MIN}

▶ Output

- V_{OUT}
- I_{OUT_max}

基础参数

▶ Output ripple/noise

- ΔV_{RIPPLE}
- V_{RMS} (10Hz to 100kHz)
- 1/f noise

▶ light load efficiency?

- $I_{LIGHT_LOAD}, \eta_{LIGHT_LOAD}$

▶ Shutdown, Power_Good

▶ Size/Height limitation

▶ Ambient temperature

▶ Design time frame 进阶参数

▶ Transient response

- Load step, BW (Bode plot)
- ΔV_{OUT}

▶ Line regulation

- ΔV_{OUT}

▶ Input reverse protection

▶ Output reverse protection (in case of battery related)

▶ Current limit, short circuit protection scheme

- Hiccup, current foldback..

▶ Cold crank, jump start, load dump, AC superimpose etc.

▶ EMC/EMI specification

- Industrial/International standard

▶ Special requirements

- PSM, I²C, current readback (digital/analog)
- Sequencing, tracking
- Margining
- Watchdog

专业级参数



电源设计，到底是简单还是复杂



5V, 2MHz Step Down

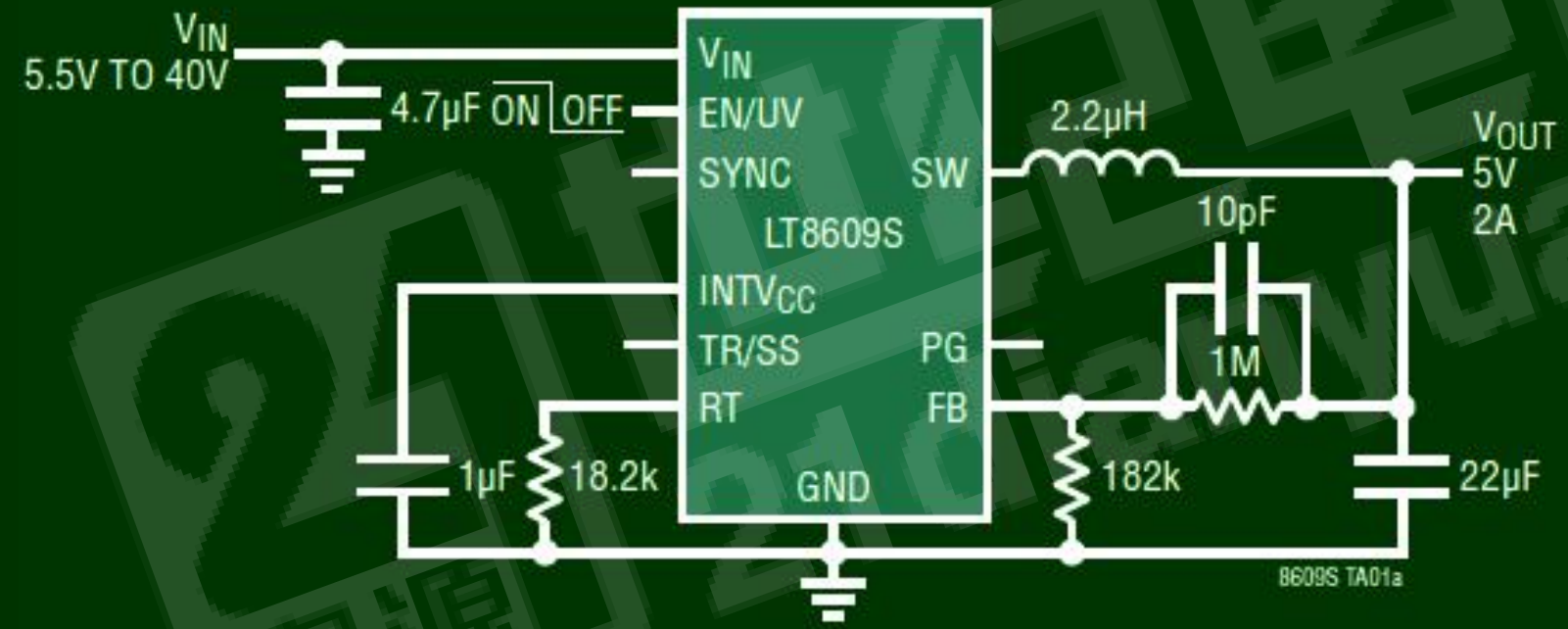



电源设计，到底是简单还是复杂

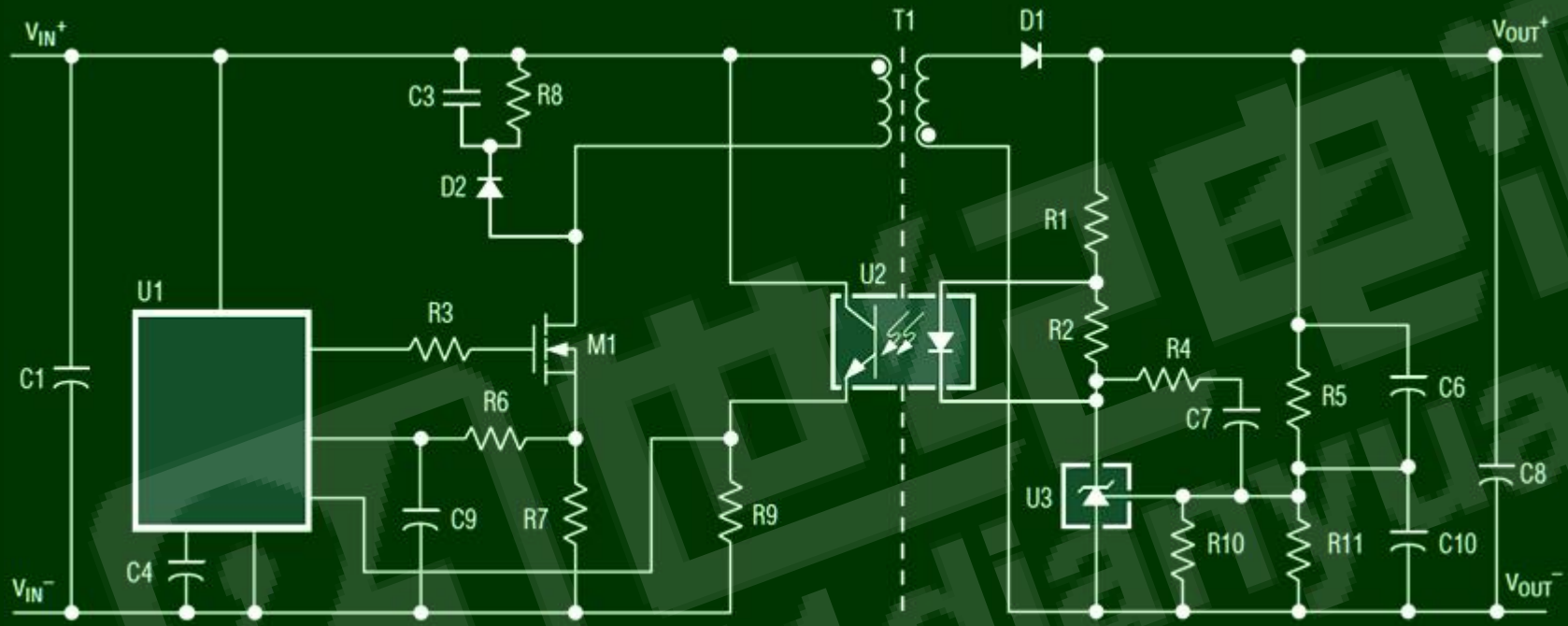

↑
Primary Side IC

↑
Opto

↑
Secondary Side Reference and Loop Compensation



电源设计，到底是简单还是复杂





简化电源设计，加速产品研发

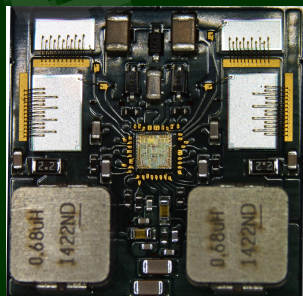
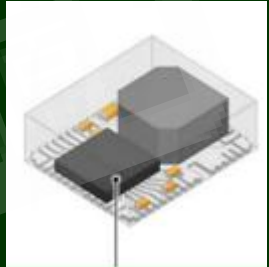
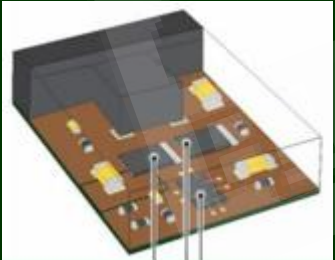
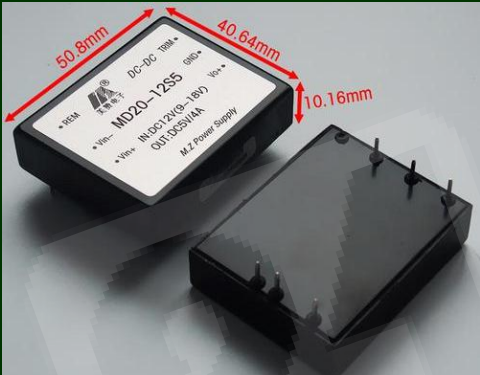
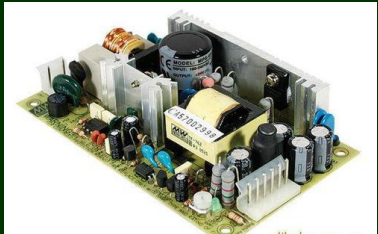



电源模块的应用及要求



21世纪电源网
21dianyuan.com

电源模块的应用

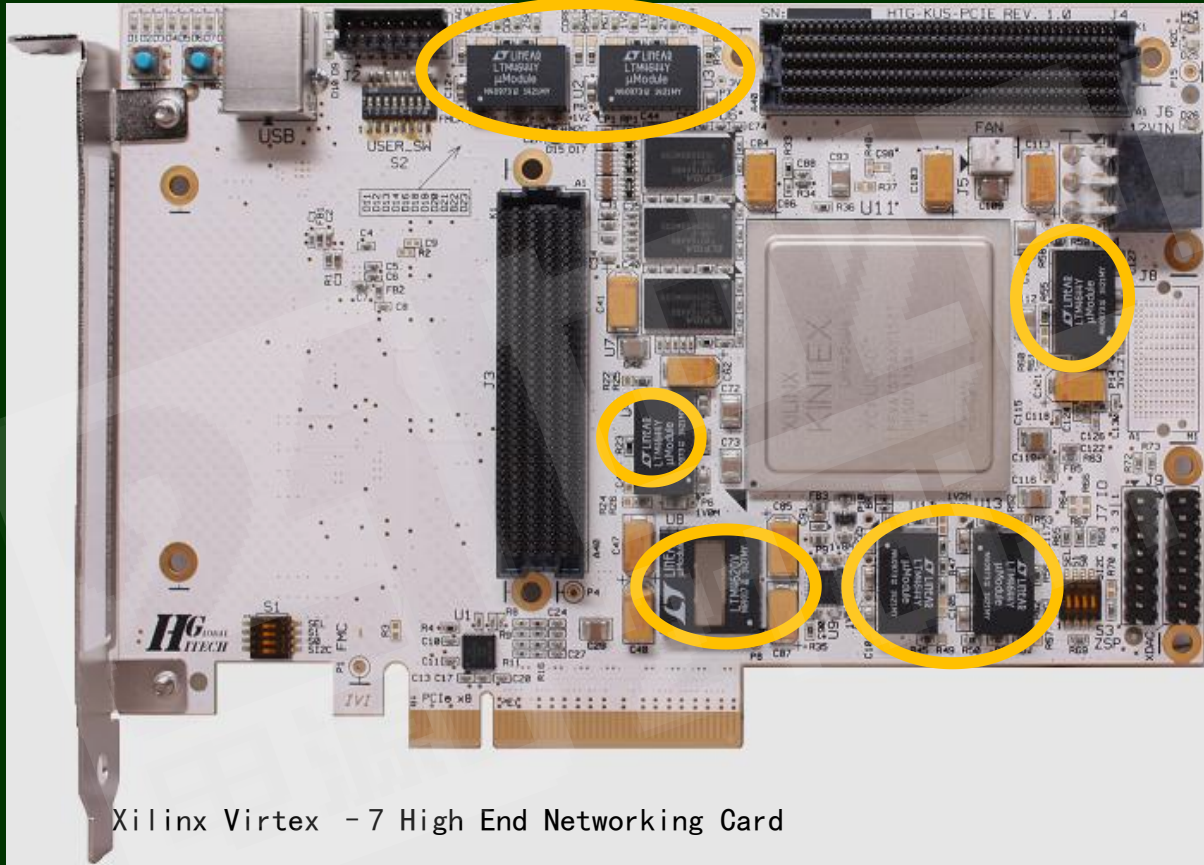

Xilinx Virtex - 7 High End Networking Card

电源模块的设计要求

Performance
3 Key Metrics

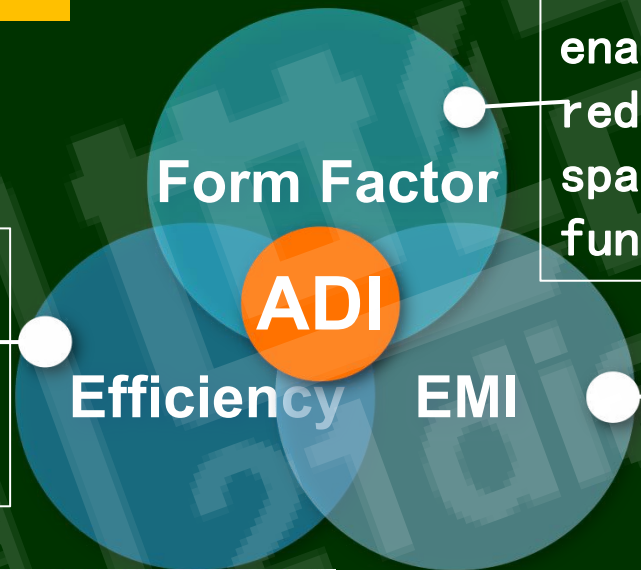
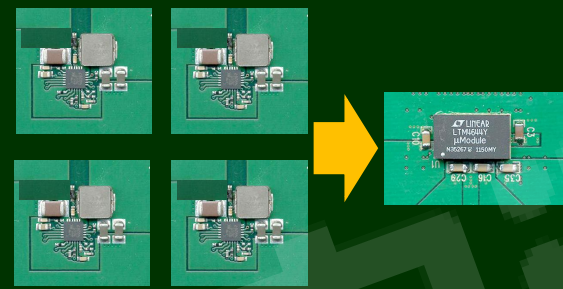

Reduce form factor enabling customers to reduce PCB space or add incremental functionality

Manage power dissipation (heat) in the smallest of form factors

Reduce electromagnetic interference (noise)

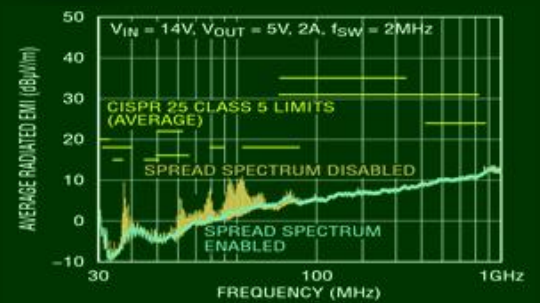
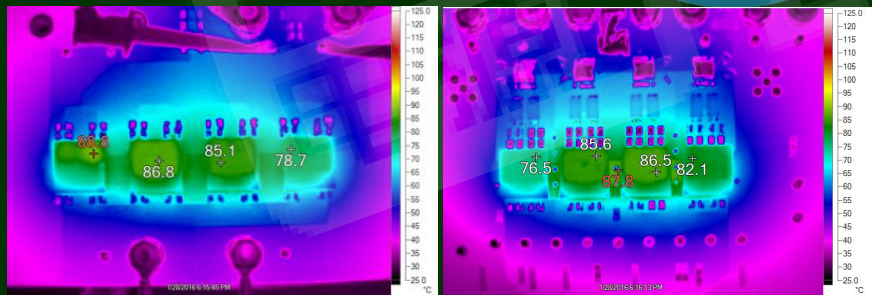



微型电源模块的设计及挑战

成本 EMI 封装 散热

不是随便一个电源方案都适合做模块

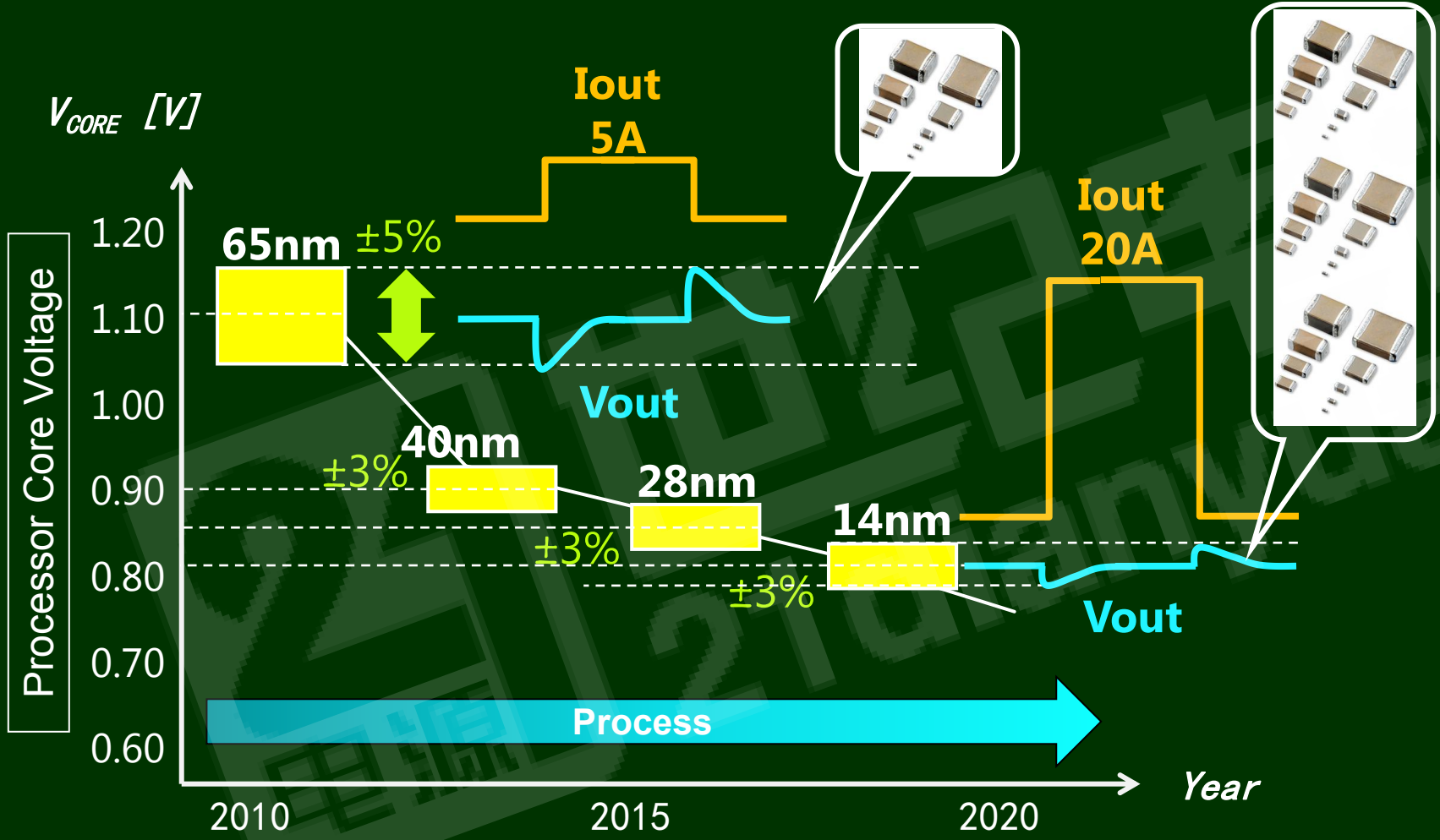

方案对成本的影响

成本分析

Example: Vin 12V (Battery) → Vout 5V/4A & 3.3V/4A



Competitor

Device	1pc
Capacitor	32pcs
Resistor	22pcs
Inductor	2pcs
FET	4pcs
Diode	4pcs
Total	65pcs

ADI / LT8650S

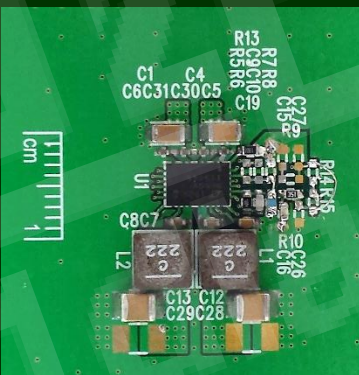

Device	1cs
Capacitor	14pcs
Resistor	7pcs
Inductor	2pcs
Total	24pcs

Save \$



Low EMI DC/DDC Technology



21世纪电源网
21dianyuan.com

EMI 来源

- ▶ With monolithic switcher, the best way is to place the low ESL input capacitor as close to the V_{IN} and GND as possible
- ▶ A solid GND plane with minimum distance to the hot loop is one of the most effective ways to reduce EMI

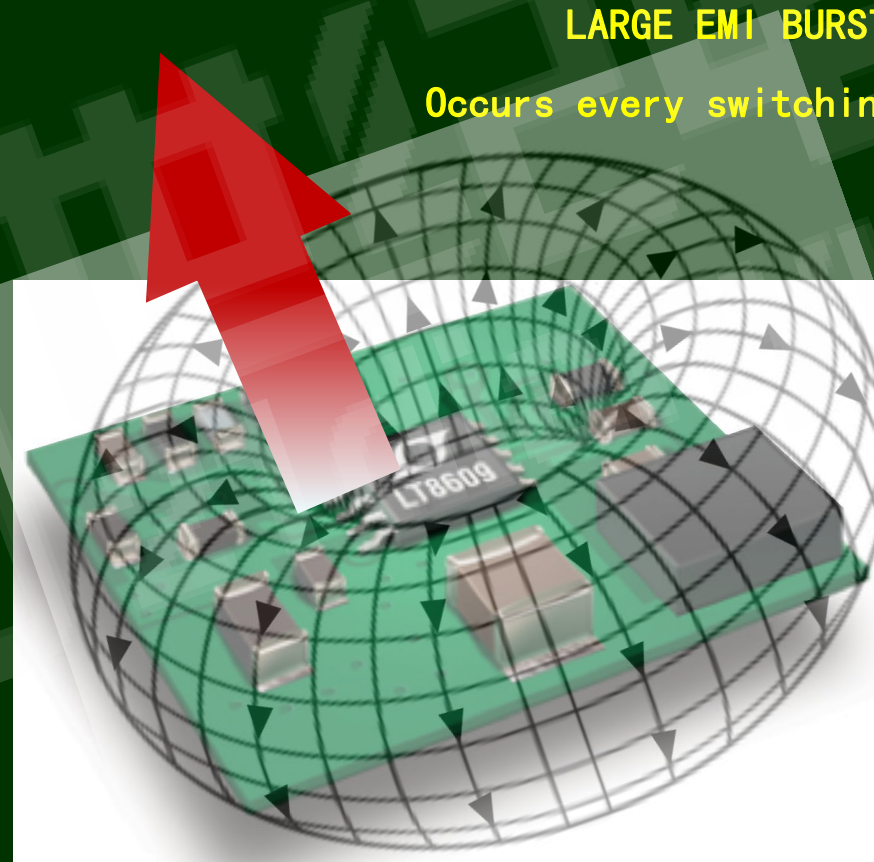
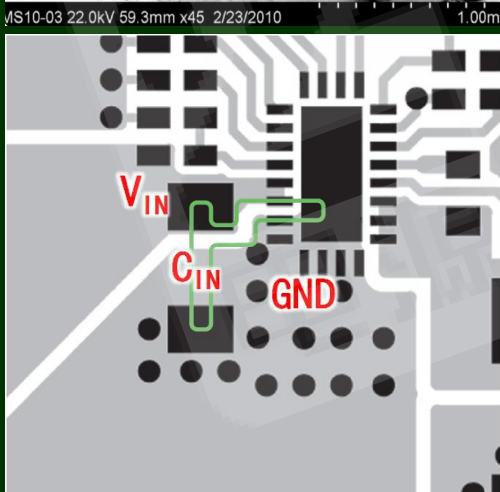
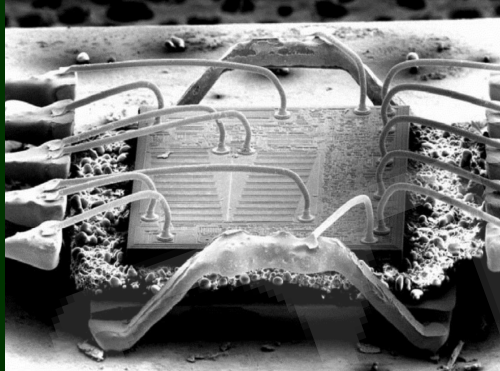

LARGE EMI BURST!

Occurs every switching cycle!



Innovation – Silent Switcher 1

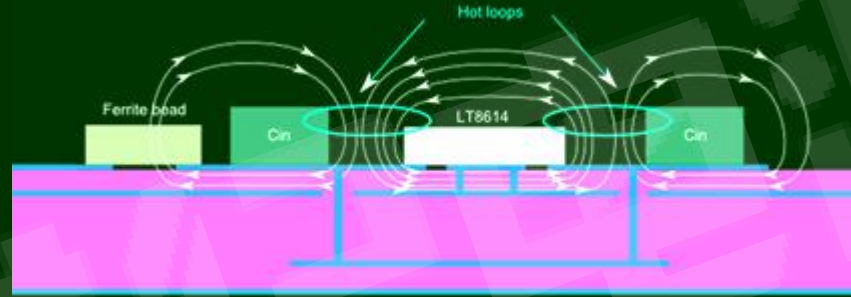
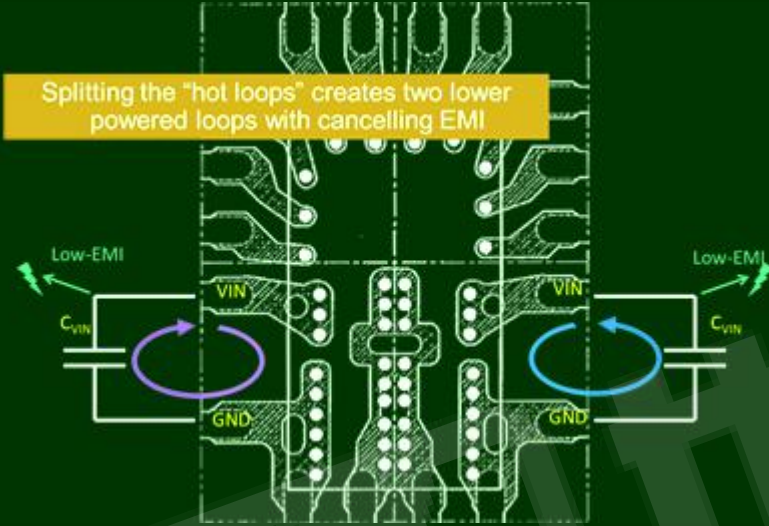

- ◆ The two high current loops cancel each others magnetic field, almost like enclosing the circuit in a metal box

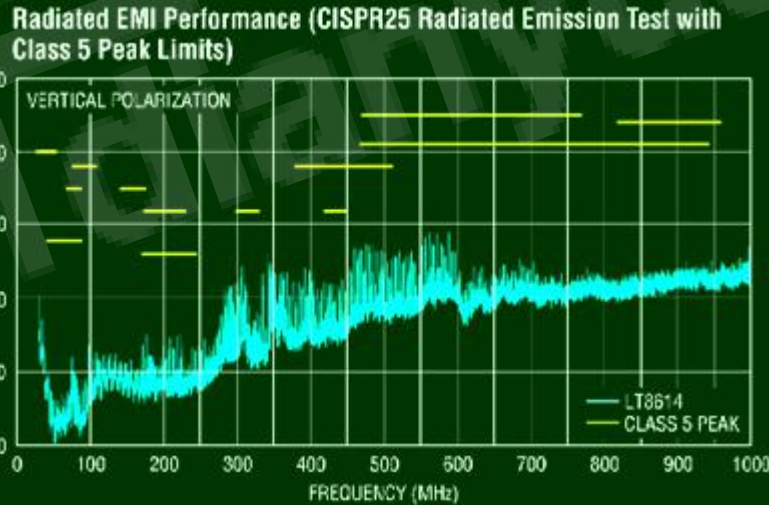

Innovation – Magnetic Field Cancellation

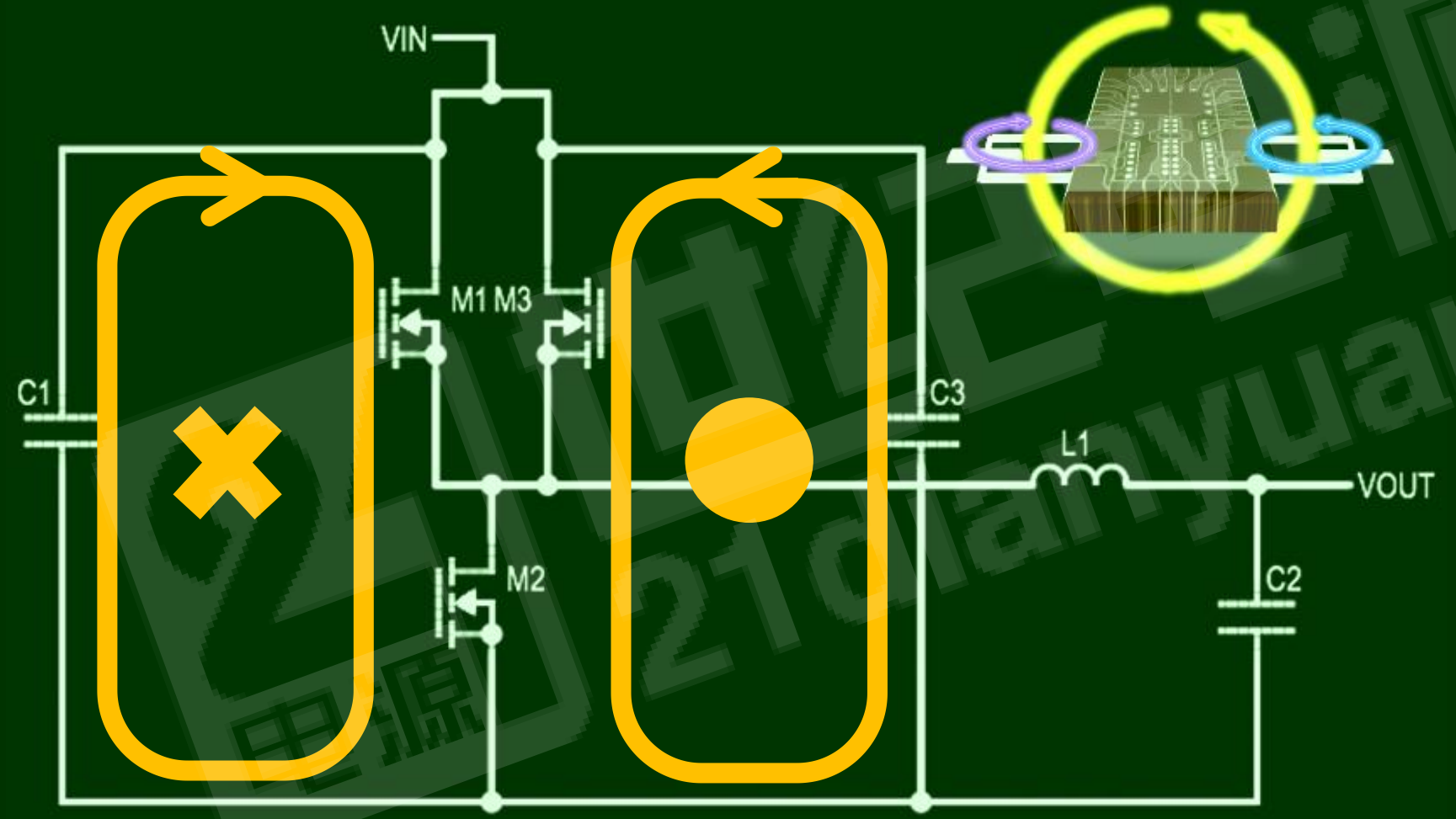

源网
21ic.com

Silent Switcher 1 Eliminates Switch Ringing

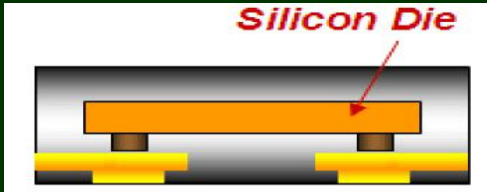

LT8610: Wirebonded in MS16E

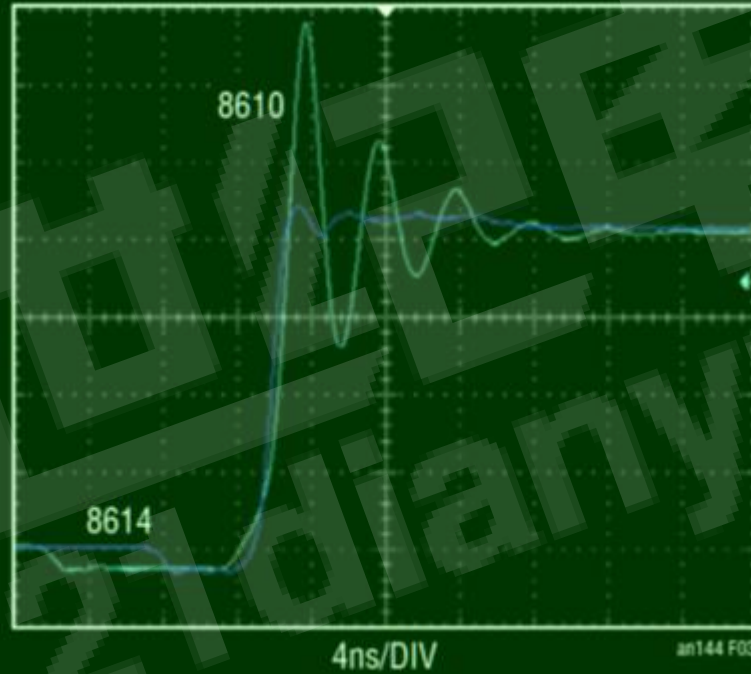
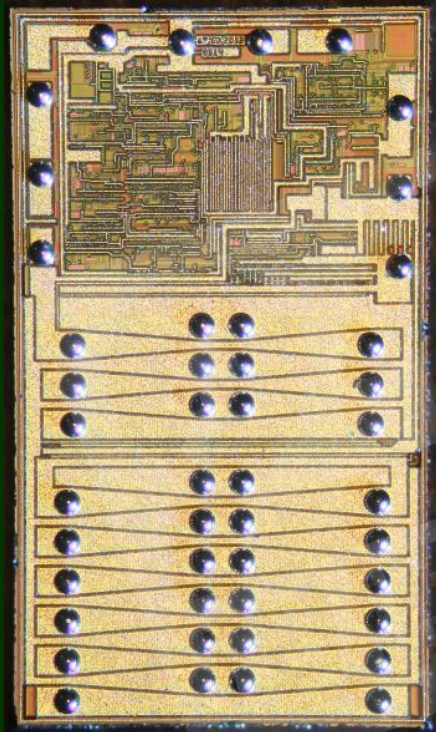

LT8614: Silent Switcher
1: Magnetic cancellation
+ CuPillar Flip-Chip

Innovation – Silent Switcher 1

5V 5A Step-Down Converter

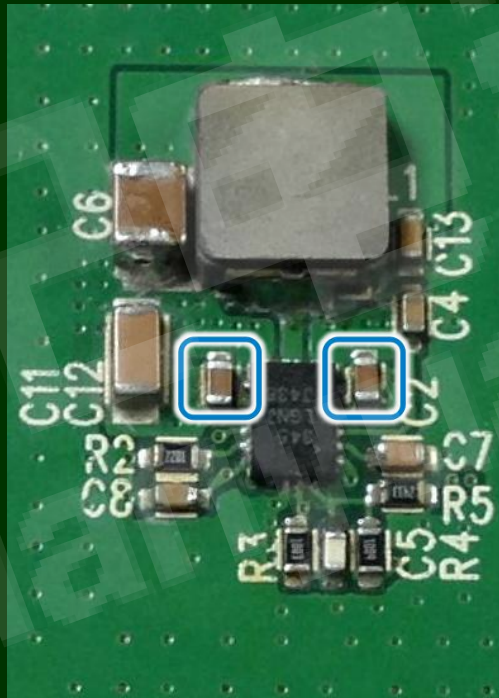
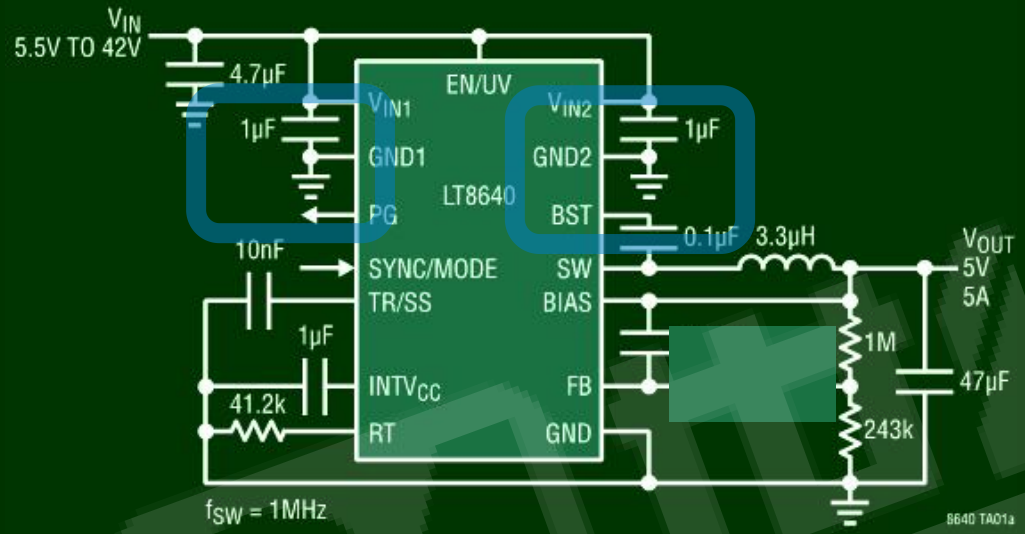

The layout is critical though!

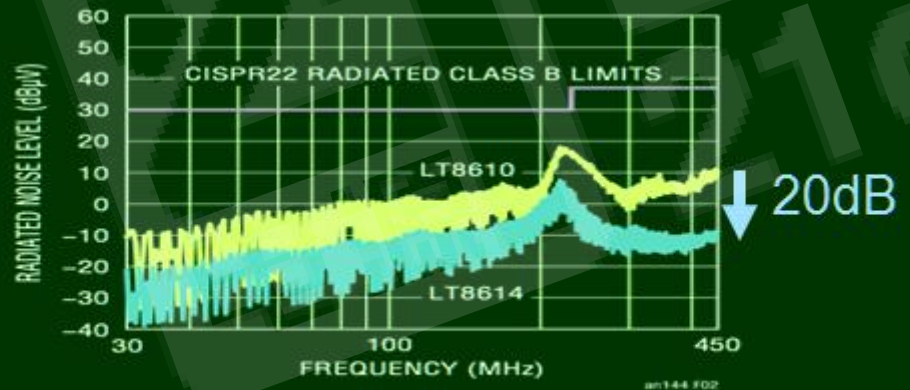

Figure 2. LT8610 and LT8614 700kHz 14V to 3.3V 2A Radiated EMI in GTEM Corrected for OATS



Silent Swither 2



21世纪电源网
21dianyuan.com

Innovation – Silent Switcher 2

Silent Switcher 1

The layout is critical though!

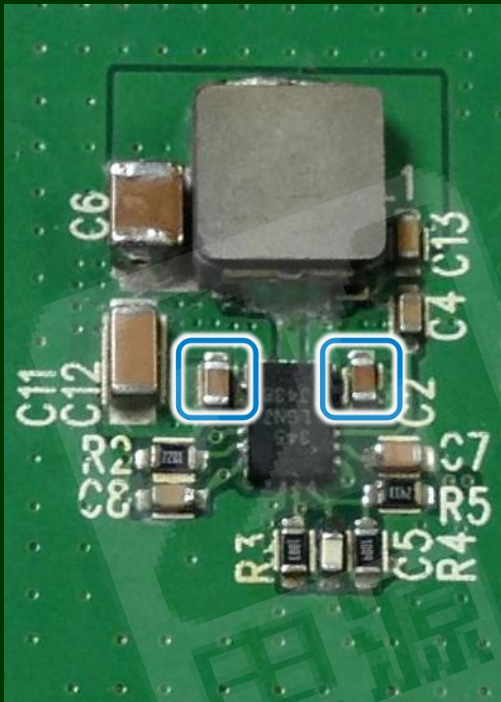

Silent Switcher 2

*Flip chip on laminate (FCOL)
and Cap-In-Package*

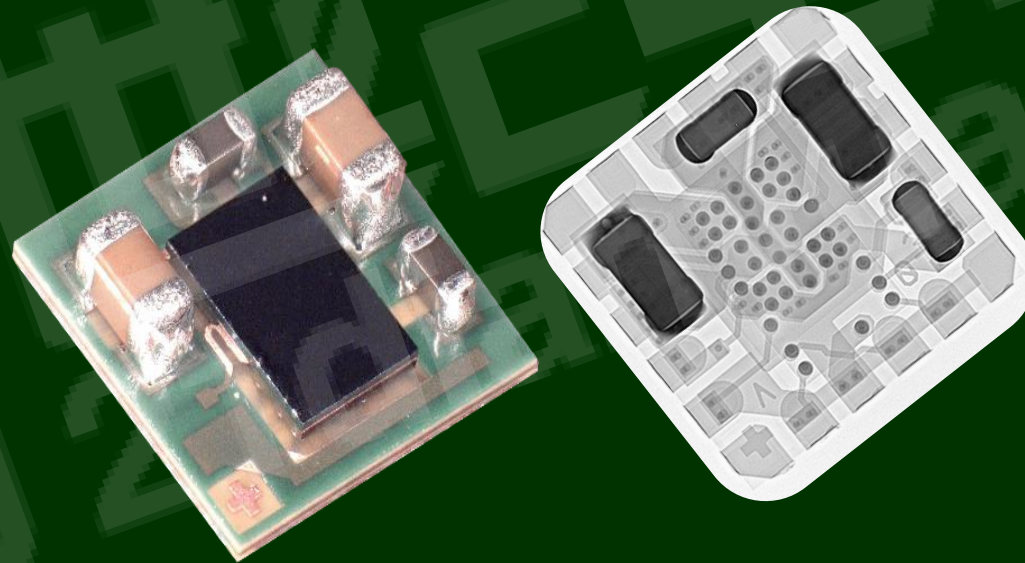

Innovation – Silent Switcher 2

No slew rate limit on switching node necessary to achieve low EMI !

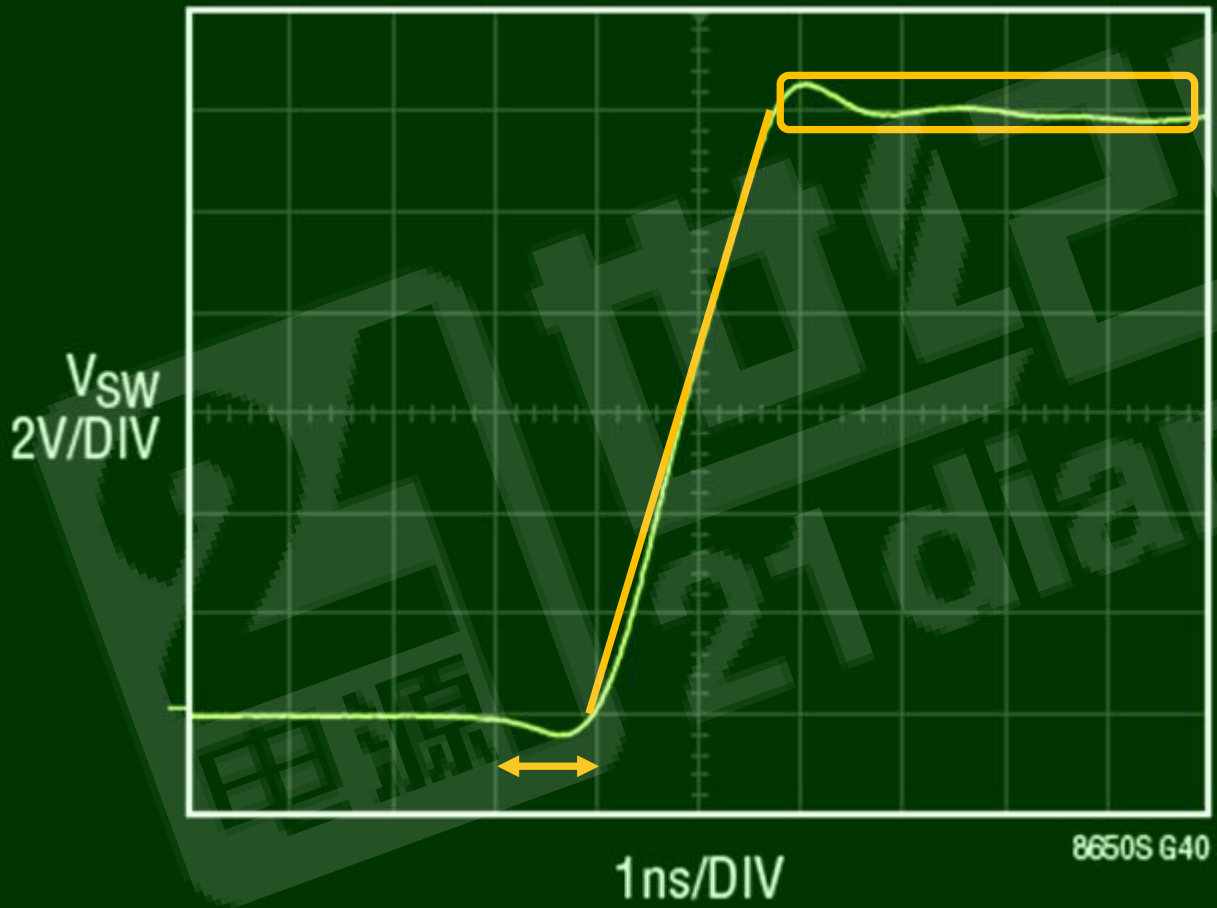



Silent Switcher 2 – Excellent EMI

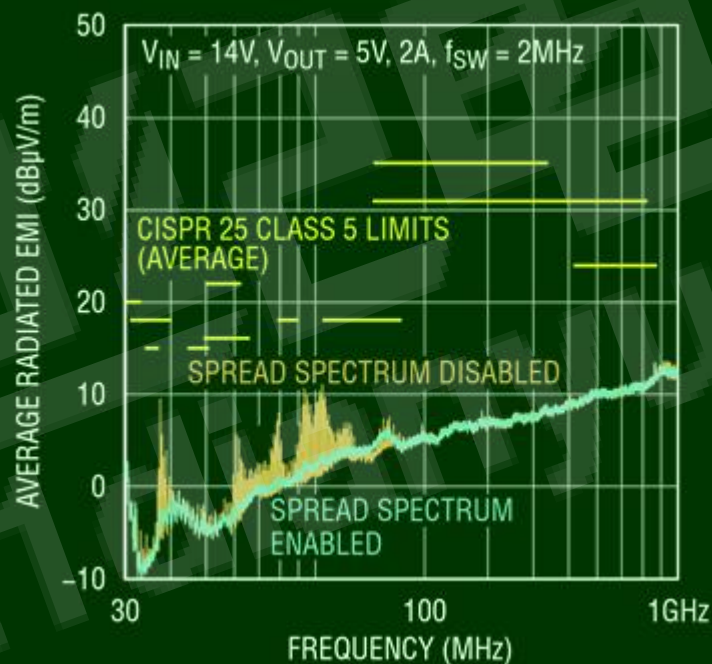
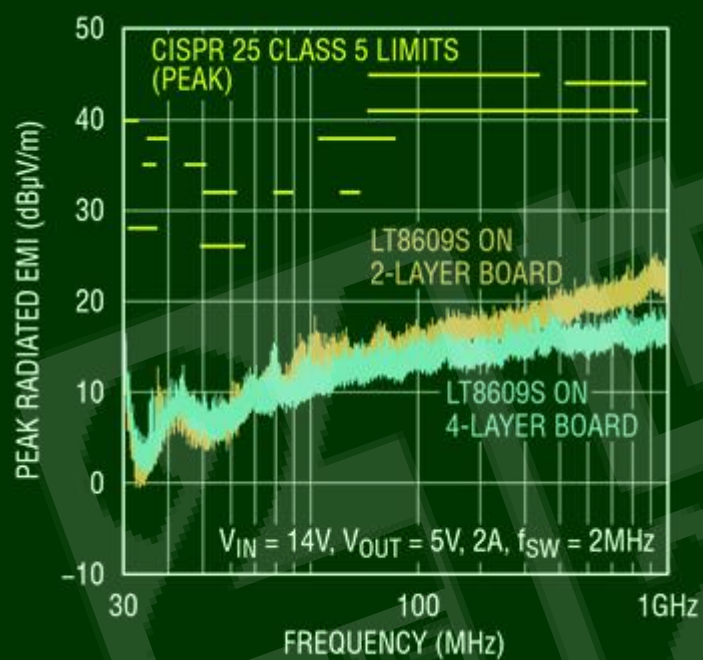



Silent Switcher 2 Also Provides Low Output Ripple



LT8609S: 12V to 5V @ 2A, 2MHz switching

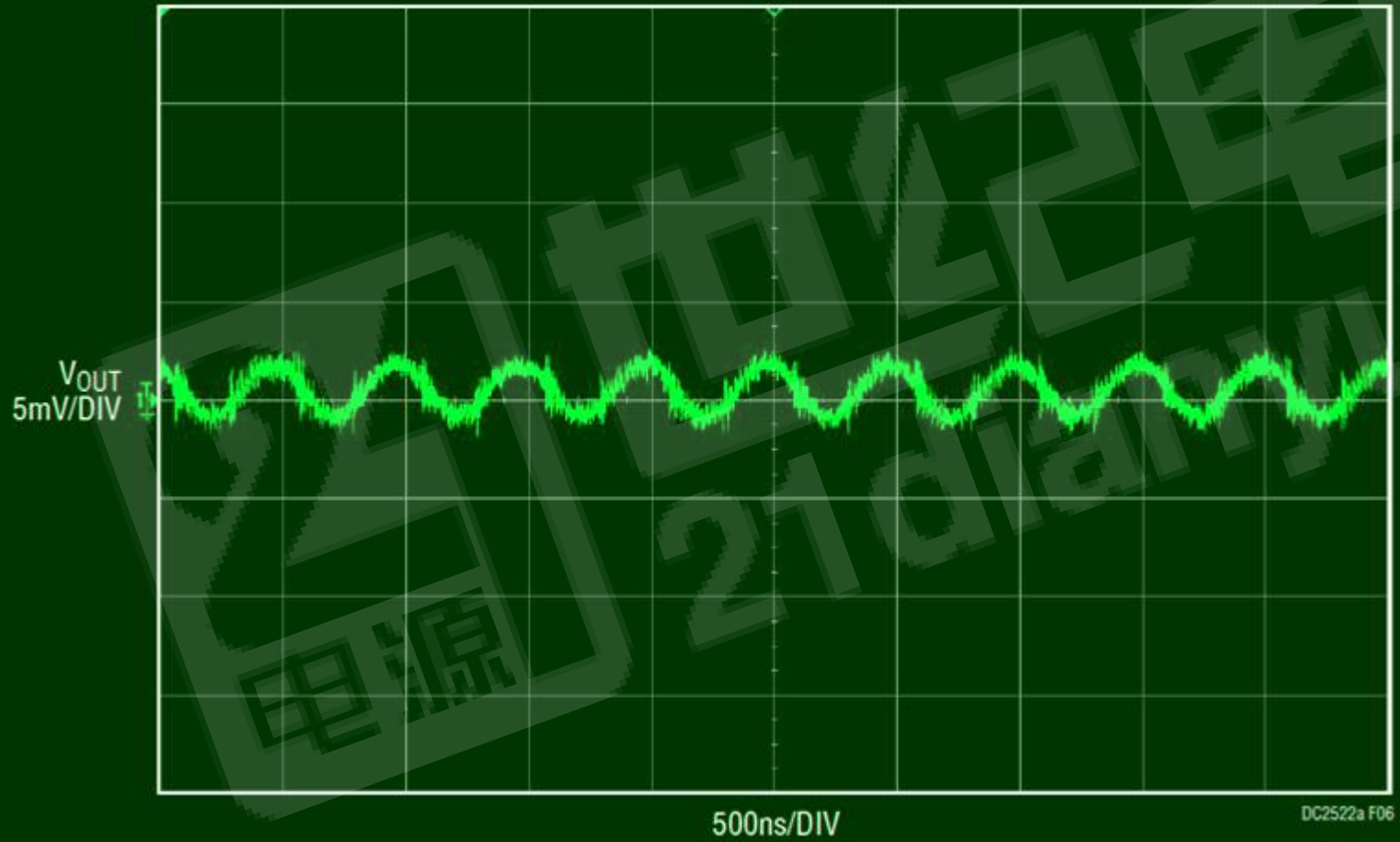

DC2522a F06



Silent Switcher Family



Part Number	Silent Switcher Family	V _{IN} Range (V)	I _{OUT} (A)	V _{OUT(MIN)} (V)	Frequency	I _Q (μA)	Package
65V_{IN(MAX)}							
LT8641	Silent Switcher	3.0 to 65	3.5	0.8	200kHz to 3MHz	2.5	3x4 QFN-18
LT8645S	Silent Switcher 2	3.4 to 65	8	0.8	200kHz to 2.2MHz	2.5	4x6 LQFN-32
42V_{IN(MAX)}							
LT8606	Low EMI	3.0 to 42	350mA	0.8	200kHz to 2.2MHz	3	2x2 DFN, MSOP10E
LT8607	Low EMI	3.0 to 42	750mA	0.8	200kHz to 2.2MHz	3	2x2 DFN, MSOP10E
LT8608	Low EMI	3.0 to 42	1.5	0.8	200kHz to 2.2MHz	2.5	2x2 DFN, MSOP10E
LT8609S	Silent Switcher 2	3.0 to 42	2/3 Peak	0.8	200kHz to 2.2MHz	2.5	3x3 LQFN-16
LT8609A	Low EMI	3.0 to 42	2/3 Peak	0.8	200kHz to 2.2MHz	2.5	3x3 DFN, MSOP10E
LT8614	Silent Switcher	3.4 to 42	4	0.97	200kHz to 2.2MHz	2.5	3x4 QFN-18
LT8653S	Silent Switcher 2	3.0 to 42	2x2/3 Peak	0.8	200kHz to 3MHz	6	3x4 LQFN-20
LT8640/-1	Silent Switcher	3.4 to 42	5/7 Peak	0.97	200kHz to 3MHz	2.5	3x4 QFN-18
LT8640S	Silent Switcher 2	3.4 to 42	5/7 Peak	0.97	200kHz to 3MHz	2.5	4x4 LQFN-24
LT8643S	Silent Switcher 2	3.4 to 42	5/7 Peak	0.97	200kHz to 3MHz	230	4x4 LQFN-24
LT8650S	Silent Switcher 2	3.0 to 42	2x4/6 Peak	0.8	200kHz to 3MHz	6.2	4x6 LQFN-32
LT8648S	Silent Switcher 2	3.0 to 42	15	0.6	200kHz to 3MHz	6	4x7 LQFN-36
18V_{IN(MAX)}							
LT8642S	Silent Switcher 2	2.8 to 18	10	0.6	200kHz to 3MHz	240	4x4 LQFN-24
LTC7151S	Silent Switcher 2	3.1 to 20	15	0.6	400kHz to 3MHz	2mA	4x5 LQFN-28
LTC7150S	Silent Switcher 2	3.1 to 20	20	0.6	400kHz to 3MHz	2mA	5x6 BGA-42
LT8652S	Silent Switcher 2	3.0 to 18	8+8	0.6	300kHz to 3MHz	6	4x7 LQFN-36
5V_{IN(MAX)}							
LTC3307/8/9	Silent Switcher	2.25 to 5.5	3/4/6	0.5	500kHz to 5MHz	45	2x2 LQFN-12
LTC3315	Silent Switcher	2.25 to 5.5	2+2	0.5	500kHz to 5MHz	70	2x2 LQFN-12
LTC3310S	Silent Switcher 2	2.25 to 5.5	10	0.5	500kHz to 5MHz	1.3mA	3x3 LQFN-18
LT8647S	Silent Switcher 2	2.8 to 8	7	0.6	300kHz to 4MHz	140	3x4 LQFN-20
LT8644S	Silent Switcher 2	2.8 to 8	15	0.6	300kHz to 4MHz	145	4x4 LQFN-24

DEVICE	OUT PUTS	V _{IN} RANGE	OUTPUT CURRENT	PEAK EFFICEINCY	I _Q	FEATURES	PACKAGES
LT8650S	2	3V – 42V	4A + 4A on both channels	94.60%	6.2μA	Silent Switcher 2	6mm x 4mm x 0.95mm LQFN
LT8645S	1	3.4V – 65V	8A	94%	2.5μA	Silent Switcher 2	6mm x 4mm x 0.95mm LQFN
LT8643S	1	3.4V – 42V	6A continuous 7A peak	95%	120μA	Silent Switcher 2, external compensation	4mm x 4mm x 0.94mm LQFN
LT8640S	1	3.4V – 42V	6A continuous 7A peak	95%	2.5μA	Silent Switcher 2	4mm x 4mm x 0.94mm LQFN
LT8609S	1	3V – 42V	2A continuous 3A peak	93%	2.5μA	Silent Switcher 2	3mm x 3mm x 0.94mm LQFN
LT8640	1	3.4V – 42V	5A continuous 7A peak	95%	2.5μA	Silent Switcher, LT8640 pulse skipping,	3mm x 4mm QFN-18
LT8641	1	3V – 65V	3.5A continuous 5A peak	94%	2.5μA	Silent Switcher	3mm x 4mm QFN-18
LT8614	1	3.4V – 42V	4A	94%	2.5μA	Silent Switcher. Low ripple Burst Mode operation	3mm x 4mm QFN-18



Improve efficiency



TYPICAL APPLICATION

5V 8A Step-Down Converter

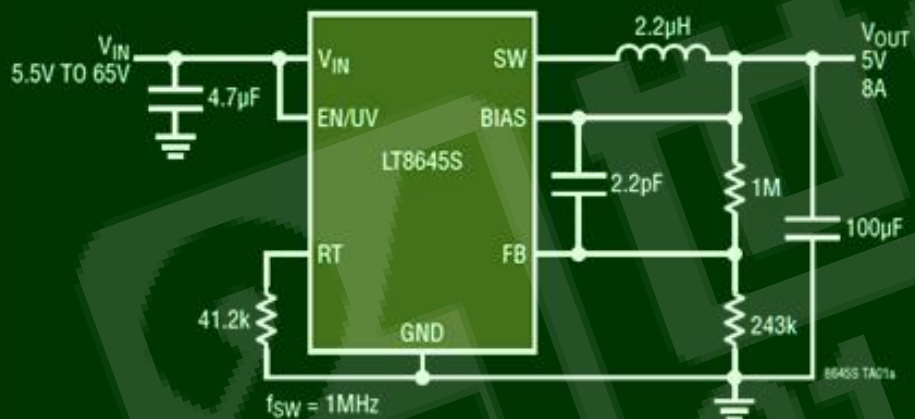

12VIN to 5VOUT Efficiency

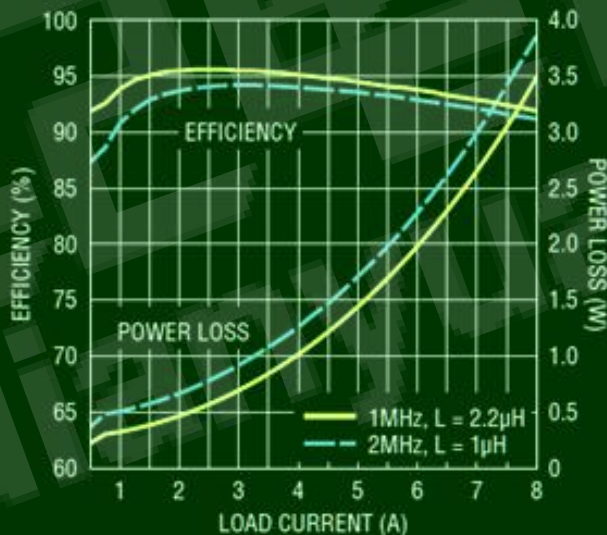

Improve efficiency

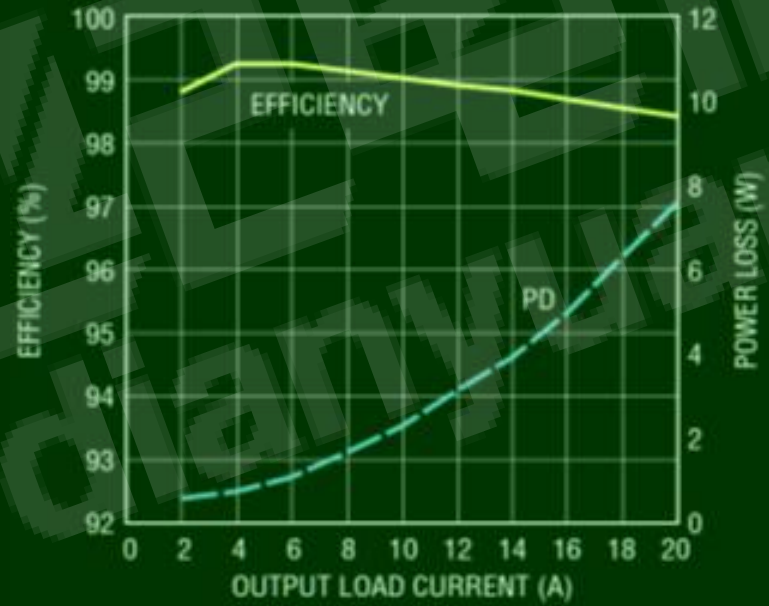
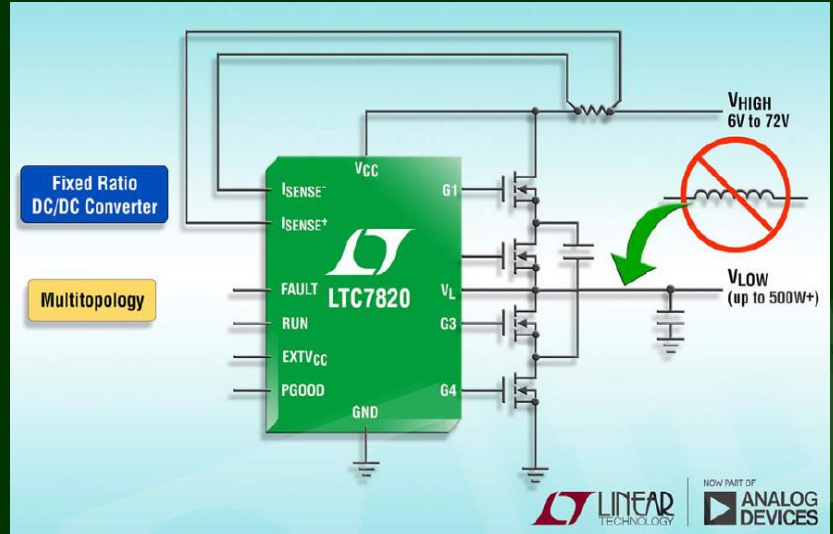

Inductorless Bus Converter

99% Efficient Step-Down, Step-Up or Invert

Improve efficiency

Switched Capacitor

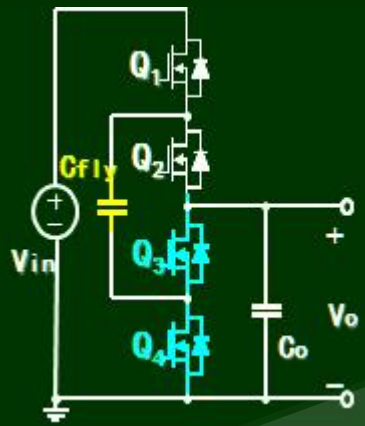

Synchronous Buck

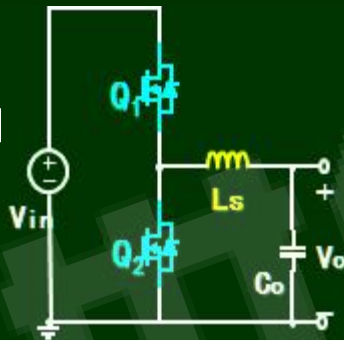

❖ Hybrid Converter

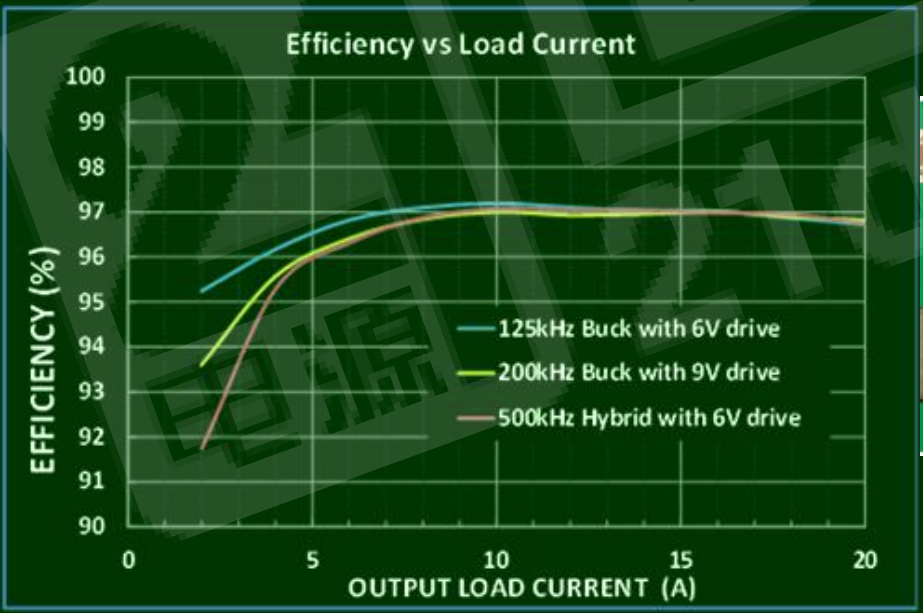
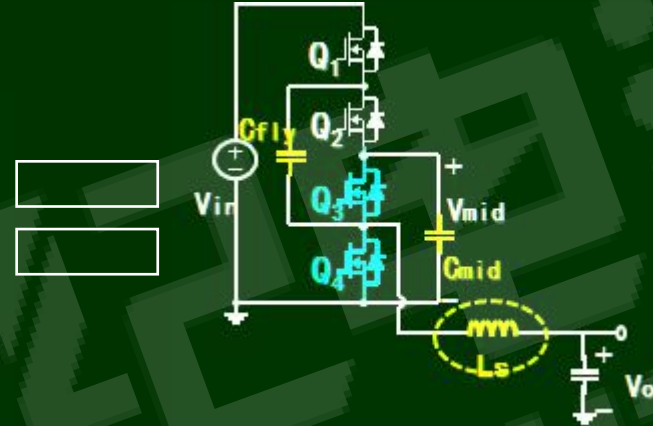



封装与散热



21 电源网
21dianyuan.com

功率密度与尺寸及效率（散热）有很大关系

FPGA Core 0.8V @100A
Power Supplier Solution



Year 2012

4x LTM46



Year 2014

3x LTM46



Year 2016

2x LTM46



1 x LTM4700
(July 2018)





功率密度与尺寸及效率（散热）有很大关系



10A-12A

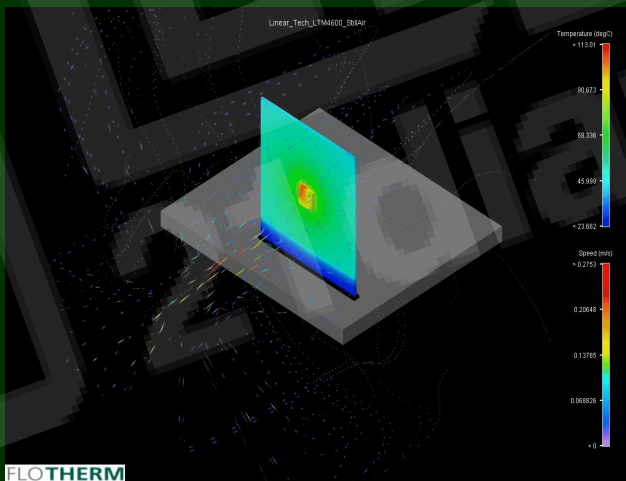
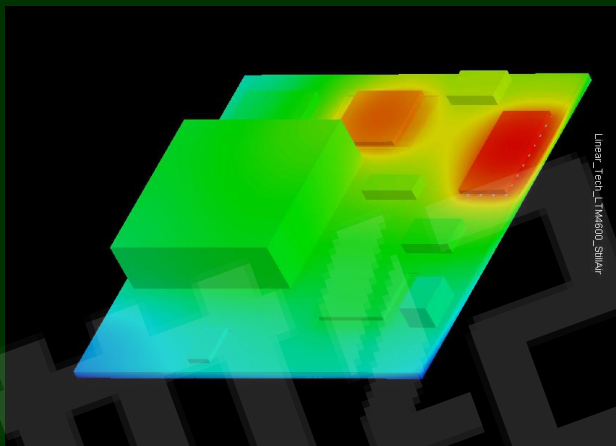
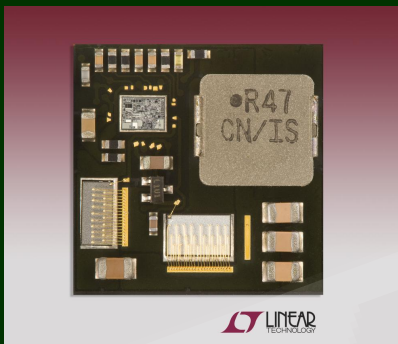



功率密度与尺寸及效率（散热）有很大关系



26A-50A

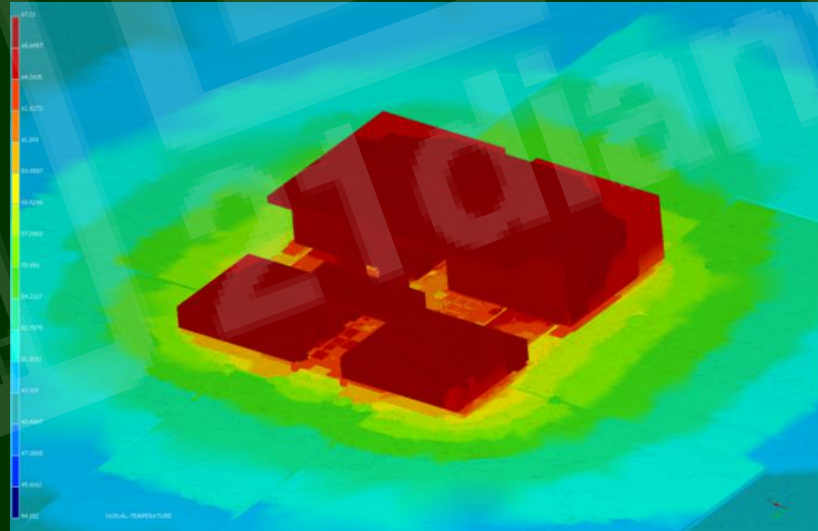
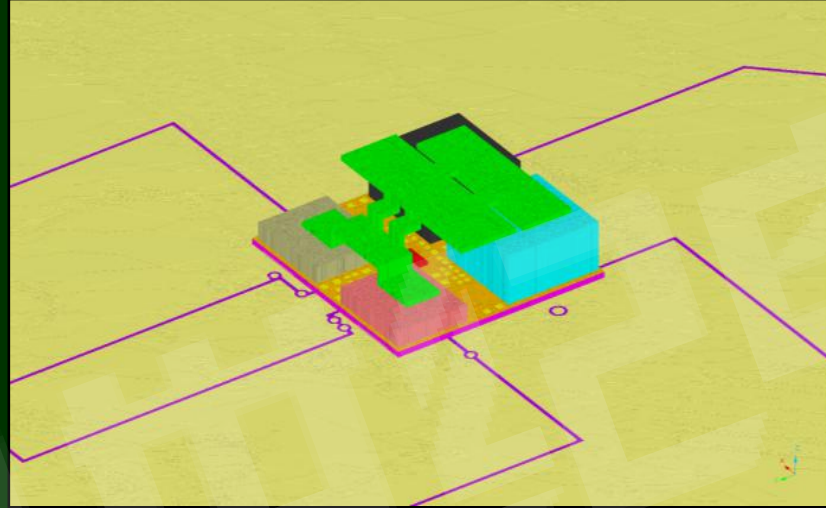
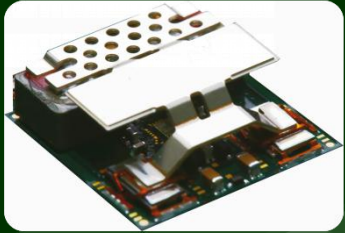

电源网
yuan.com

功率密度与尺寸及效率（散热）有很大关系



40A+

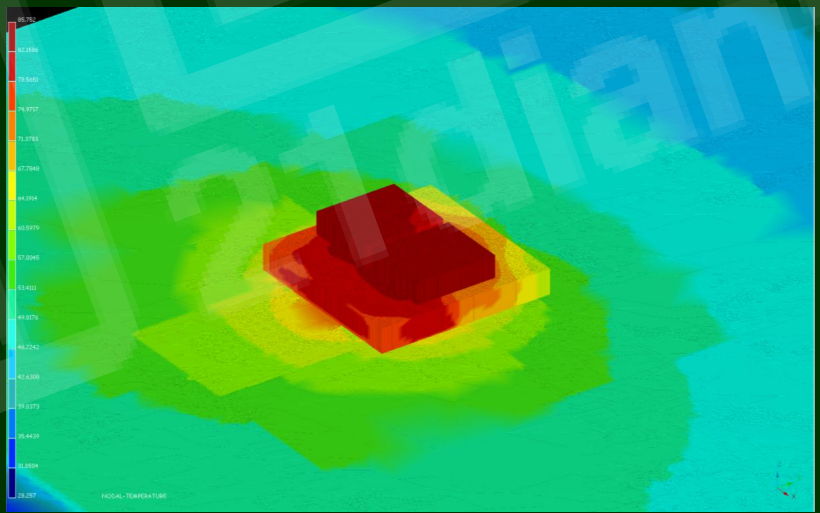
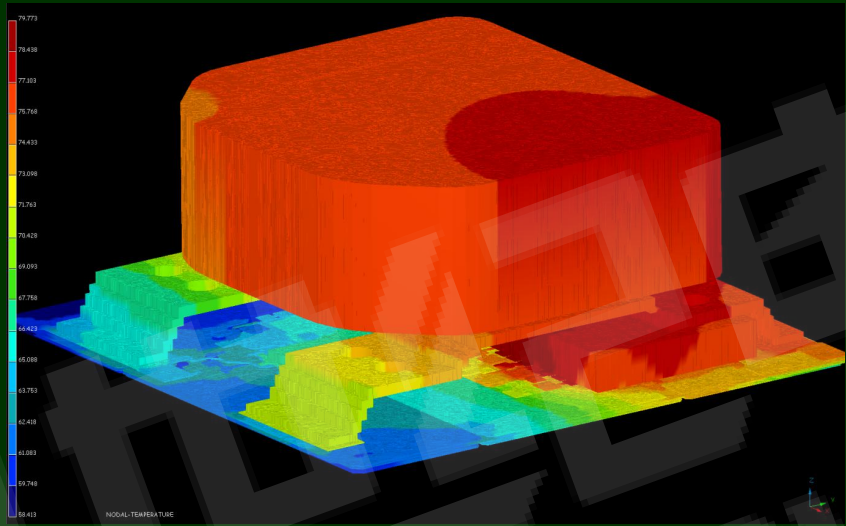
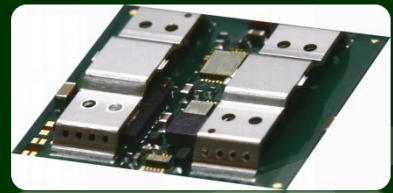



功率密度与尺寸及效率（散热）有很大关系

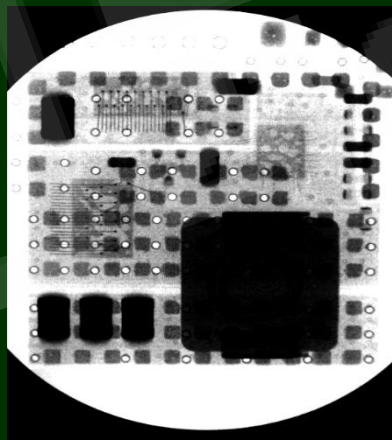
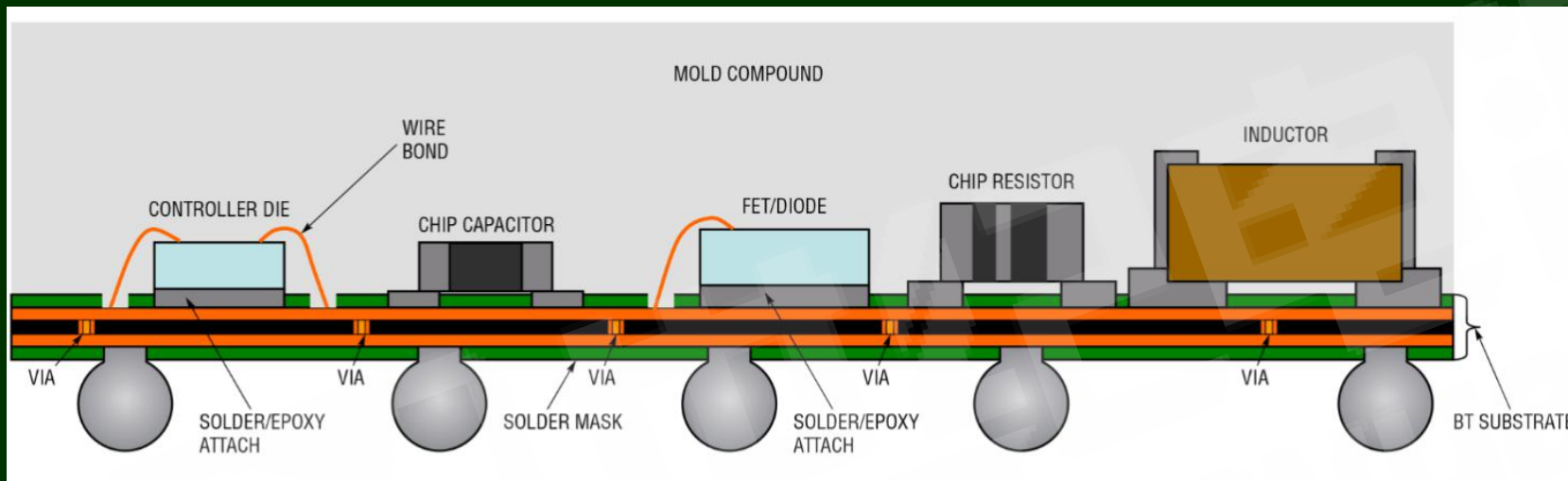



封装可靠性问题



SIP LOT M1

PHOTO NO: 1
MAG: X600
COMMENTS:
BALL DIAMETER OK
= 5.67 mls

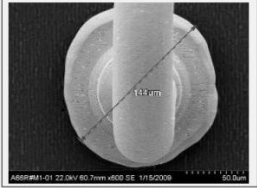

PHOTO NO: 2
MAG: X600
COMMENTS:
BALL DIAMETER OK
= 5.59 mls

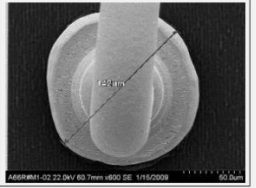

PHOTO NO: 3
MAG: X420
COMMENTS:
STITCH PROFILE TOP VIEW OK

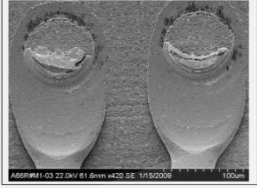
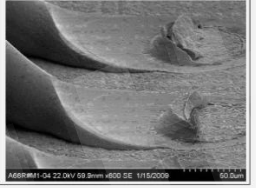

PHOTO NO: 4
MAG: X600
COMMENTS:
STITCH PROFILE TILTED VIEW OK



SIP LOT M1

PHOTO NO: 5
MAG: X800
COMMENTS:
BALL THICKNESS = 1.34 mls

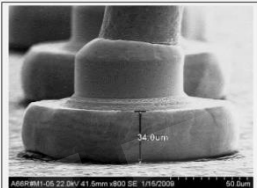

PHOTO NO: 6
MAG: X800
COMMENTS:
BALL THICKNESS = 1.27 mls

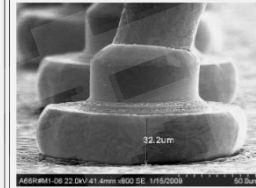

PHOTO NO: 7
MAG: X200
COMMENTS:
LOOP HEIGHT OK = 13.2 mls

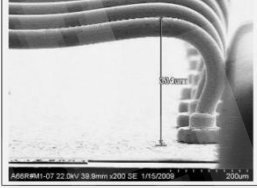

PHOTO NO: 8
MAG: X100
COMMENTS:
LOOP HEIGHT OK = 14.3 mls

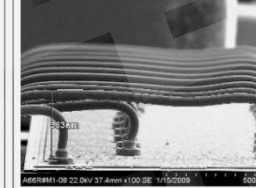

PHOTO NO: 9
MAG: X45
COMMENTS:
LOOP PROFILE OK



PHOTO NO: 4
MAG: X100
COMMENTS:
ACCEPTED
NO CRACK LINE





Power Supply Design Using LTpowerCAD Design Tool



21dianyuan.com



电源环路优化设计

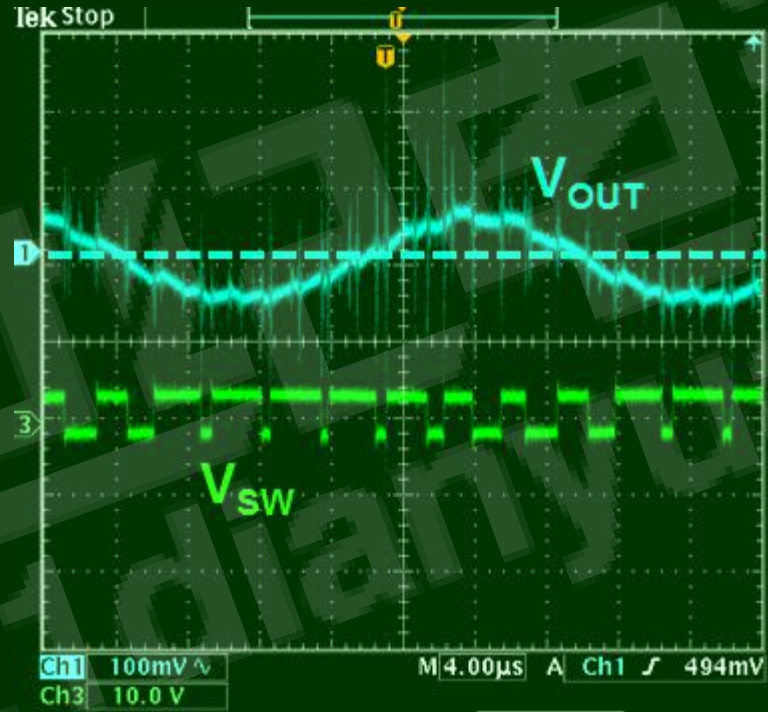
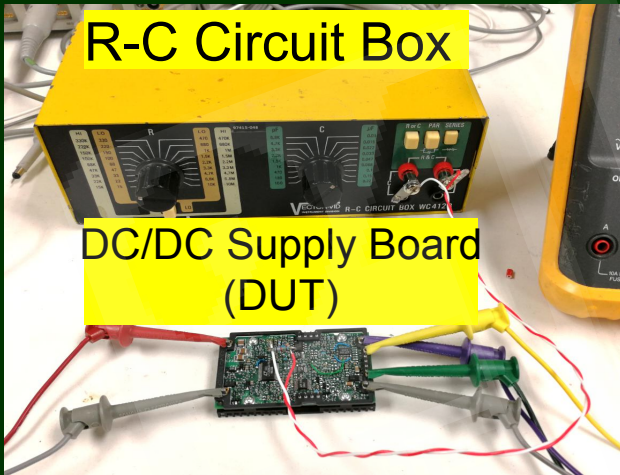
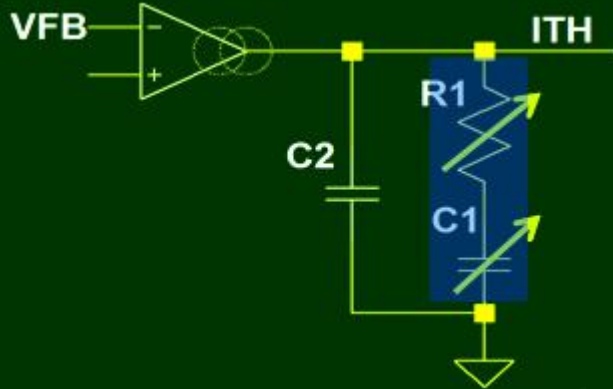

- ▶ Manually adjust R and C values.
- ▶ Check loop or load transient.
- **Accurate, but time-consuming.**

Complete Power Design Flow with Tools ...

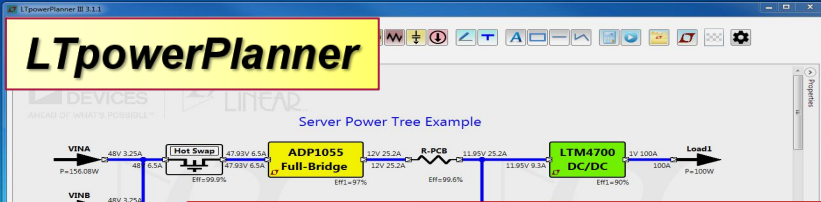

LTpowerPlanner

LTpowerCAD

Search For Parts

Design Tool	Website	Part #	Type
Web	LTC3883	Controller	
Web	LTC3854	Controller	
Web	LTC3833	Controller	
Web	LTC3851A	Controller	
Web	LTC3851A-1	Controller	
Web	LTC3770	Controller	
Web	LTC3775	Controller	
Web	LTC3778	Controller	

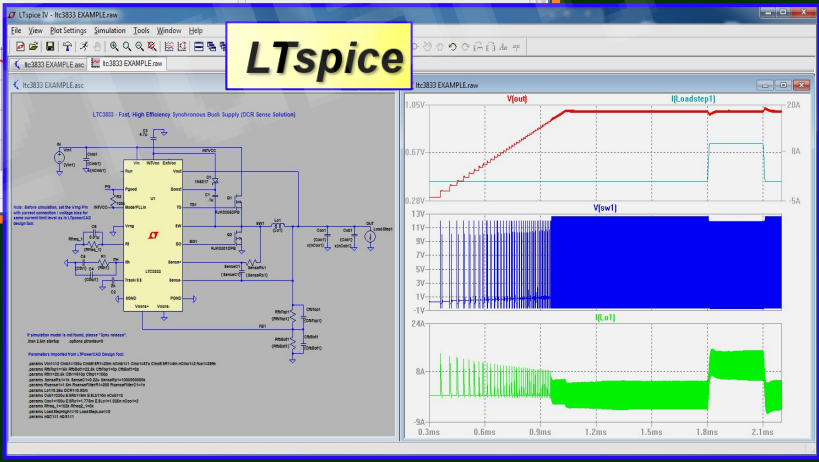
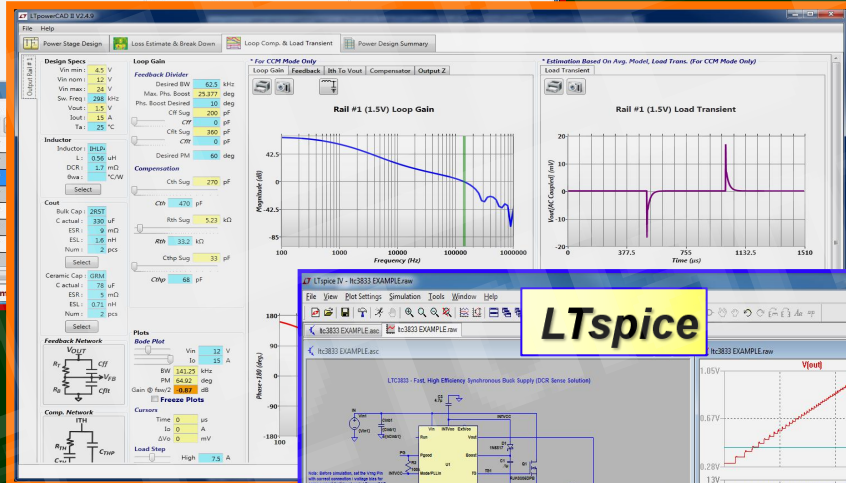

LTpowerCAD – Design Power in 5 Simple Steps!

Step 1

Step 2

Step 3

Find Solutions

Power Stage Design

Efficiency & Loss

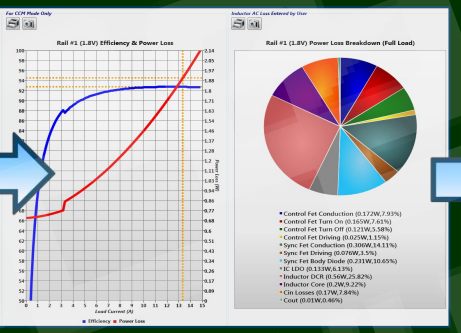
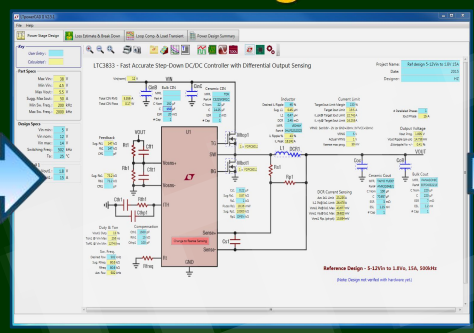
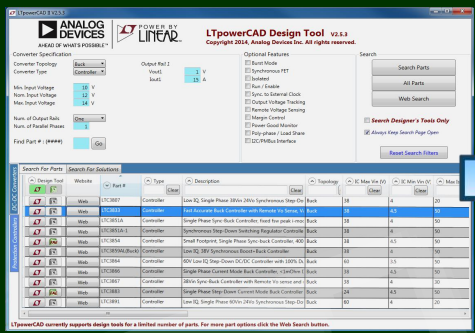

Step 4

Step 5

Loop & Transient

Summary, BOM, Size

LTspice™

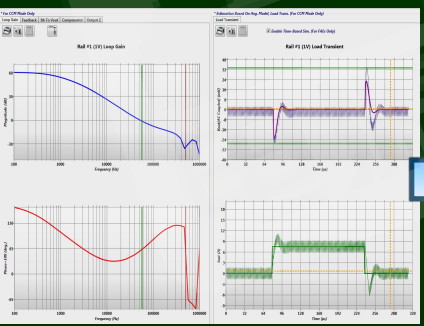

LT833 Supply Design Summary

Design Specifications

Part #	Qty	Part Name	Value	Unit	Part #	Qty	Part Name	Value	Unit
IC1	1	LT833	1.5	A	IC2	1	LT833	1.5	A
IC3	1	LT833	1.5	A	IC4	1	LT833	1.5	A
IC5	1	LT833	1.5	A	IC6	1	LT833	1.5	A
IC7	1	LT833	1.5	A	IC8	1	LT833	1.5	A
IC9	1	LT833	1.5	A	IC10	1	LT833	1.5	A
IC11	1	LT833	1.5	A	IC12	1	LT833	1.5	A
IC13	1	LT833	1.5	A	IC14	1	LT833	1.5	A
IC15	1	LT833	1.5	A	IC16	1	LT833	1.5	A
IC17	1	LT833	1.5	A	IC18	1	LT833	1.5	A
IC19	1	LT833	1.5	A	IC20	1	LT833	1.5	A
IC21	1	LT833	1.5	A	IC22	1	LT833	1.5	A
IC23	1	LT833	1.5	A	IC24	1	LT833	1.5	A
IC25	1	LT833	1.5	A	IC26	1	LT833	1.5	A
IC27	1	LT833	1.5	A	IC28	1	LT833	1.5	A
IC29	1	LT833	1.5	A	IC30	1	LT833	1.5	A
IC31	1	LT833	1.5	A	IC32	1	LT833	1.5	A
IC33	1	LT833	1.5	A	IC34	1	LT833	1.5	A
IC35	1	LT833	1.5	A	IC36	1	LT833	1.5	A
IC37	1	LT833	1.5	A	IC38	1	LT833	1.5	A
IC39	1	LT833	1.5	A	IC40	1	LT833	1.5	A
IC41	1	LT833	1.5	A	IC42	1	LT833	1.5	A
IC43	1	LT833	1.5	A	IC44	1	LT833	1.5	A
IC45	1	LT833	1.5	A	IC46	1	LT833	1.5	A
IC47	1	LT833	1.5	A	IC48	1	LT833	1.5	A
IC49	1	LT833	1.5	A	IC50	1	LT833	1.5	A
IC51	1	LT833	1.5	A	IC52	1	LT833	1.5	A
IC53	1	LT833	1.5	A	IC54	1	LT833	1.5	A
IC55	1	LT833	1.5	A	IC56	1	LT833	1.5	A
IC57	1	LT833	1.5	A	IC58	1	LT833	1.5	A
IC59	1	LT833	1.5	A	IC60	1	LT833	1.5	A
IC61	1	LT833	1.5	A	IC62	1	LT833	1.5	A
IC63	1	LT833	1.5	A	IC64	1	LT833	1.5	A
IC65	1	LT833	1.5	A	IC66	1	LT833	1.5	A
IC67	1	LT833	1.5	A	IC68	1	LT833	1.5	A
IC69	1	LT833	1.5	A	IC70	1	LT833	1.5	A
IC71	1	LT833	1.5	A	IC72	1	LT833	1.5	A
IC73	1	LT833	1.5	A	IC74	1	LT833	1.5	A
IC75	1	LT833	1.5	A	IC76	1	LT833	1.5	A
IC77	1	LT833	1.5	A	IC78	1	LT833	1.5	A
IC79	1	LT833	1.5	A	IC80	1	LT833	1.5	A
IC81	1	LT833	1.5	A	IC82	1	LT833	1.5	A
IC83	1	LT833	1.5	A	IC84	1	LT833	1.5	A
IC85	1	LT833	1.5	A	IC86	1	LT833	1.5	A
IC87	1	LT833	1.5	A	IC88	1	LT833	1.5	A
IC89	1	LT833	1.5	A	IC90	1	LT833	1.5	A
IC91	1	LT833	1.5	A	IC92	1	LT833	1.5	A
IC93	1	LT833	1.5	A	IC94	1	LT833	1.5	A
IC95	1	LT833	1.5	A	IC96	1	LT833	1.5	A
IC97	1	LT833	1.5	A	IC98	1	LT833	1.5	A
IC99	1	LT833	1.5	A	IC100	1	LT833	1.5	A

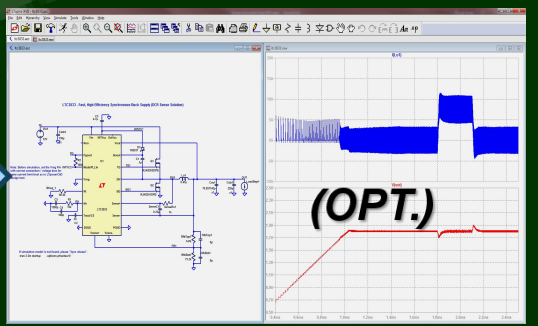

(OPT.)



LTpowerCAD Main Window



LTpowerCAD II

LTpowerCAD®

POWER BY LINEAR™

Start a New Supply Design

Supply Design System Design Simulation Open File

Toolbox Contact Help Sync/Release

LTpowerCAD II Design Tool

Copyright 2014, Analog Devices Inc. All rights reserved.

ANALOG DEVICES
AHEAD OF WHAT'S POSSIBLE™



Design Step 1- Enter Spec, Search a Part



LTpowerCAD II V2.5.2

ANALOG DEVICES POWER BY LINEAR™

LTpowerCAD Design Tool v2.5.2
Copyright 2014, Analog Devices Inc. All rights reserved.

Converter Specification

Converter Topology: Buck
 Converter Type: Controller
 Output Rail 1: Vout1 = 1 V, Iout1 = 20 A
 Min. Input Voltage: 10.8 V
 Nom. Input Voltage: 12 V
 Max. Input Voltage: 13.2 V
 Num. of Output Rails: One
 Num. of Parallel Phases: 1
 Find Part #: (####)

Optional Features

- Burst Mode
- Synchronous FET
- Isolated
- Run / Enable
- Sync. to External Clock
- Output Voltage Tracking
- Remote Voltage Sensing
- Margin Control
- Power Good Monitor
- Poly-phase / Load Share
- I2C/PMBus Interface

Search

Search Designer's Tools Only
 Always Keep Search Page Open

Search For Parts

Design Tool	Website	Part #	Type	Description	Topology	IC Max Vin (V)	IC Min Vin (V)	Max Isw/F
	Web	LTC3883	Controller	Single Phase Step-Down Current Mode Buck Controller	Buck	24	4.5	50
	Web	LTC3854	Controller	Small Footprint, Single Phase Sync-buck Controller, 400	Buck	38	4.5	50
	Web	LTC3833	Controller	Fast Accurate Buck Controller with Remote Vo Sense, Vi	Buck	38	4.5	50
	Web	LTC3851A	Controller	Single Phase Sync-Buck Controller, fixed fsw peak i-mo	Buck	38	4	50
	Web	LTC3851A-1	Controller	Synchronous Step-Down Switching Regulator Control	Buck	38	4	50
	Web	LTC3770	Controller	Valley Mode Sync-Buck Controller with Margining and I	Buck	32	4	50
	Web	LTC3775	Controller	Sync-Buck Voltage Mode DC/DC Controller. Low Ton_m	Buck	38	4.5	50
	Web	LTC3778	Controller	Valley current mode buck regulator. Use LTC3878/3879	Buck	36	4	50

LTpowerCAD currently supports design tools for a limited number of parts. For more part options click the Web Search button.

Step 2 – Power Stage Design – f_{SW}, L, C, etc.

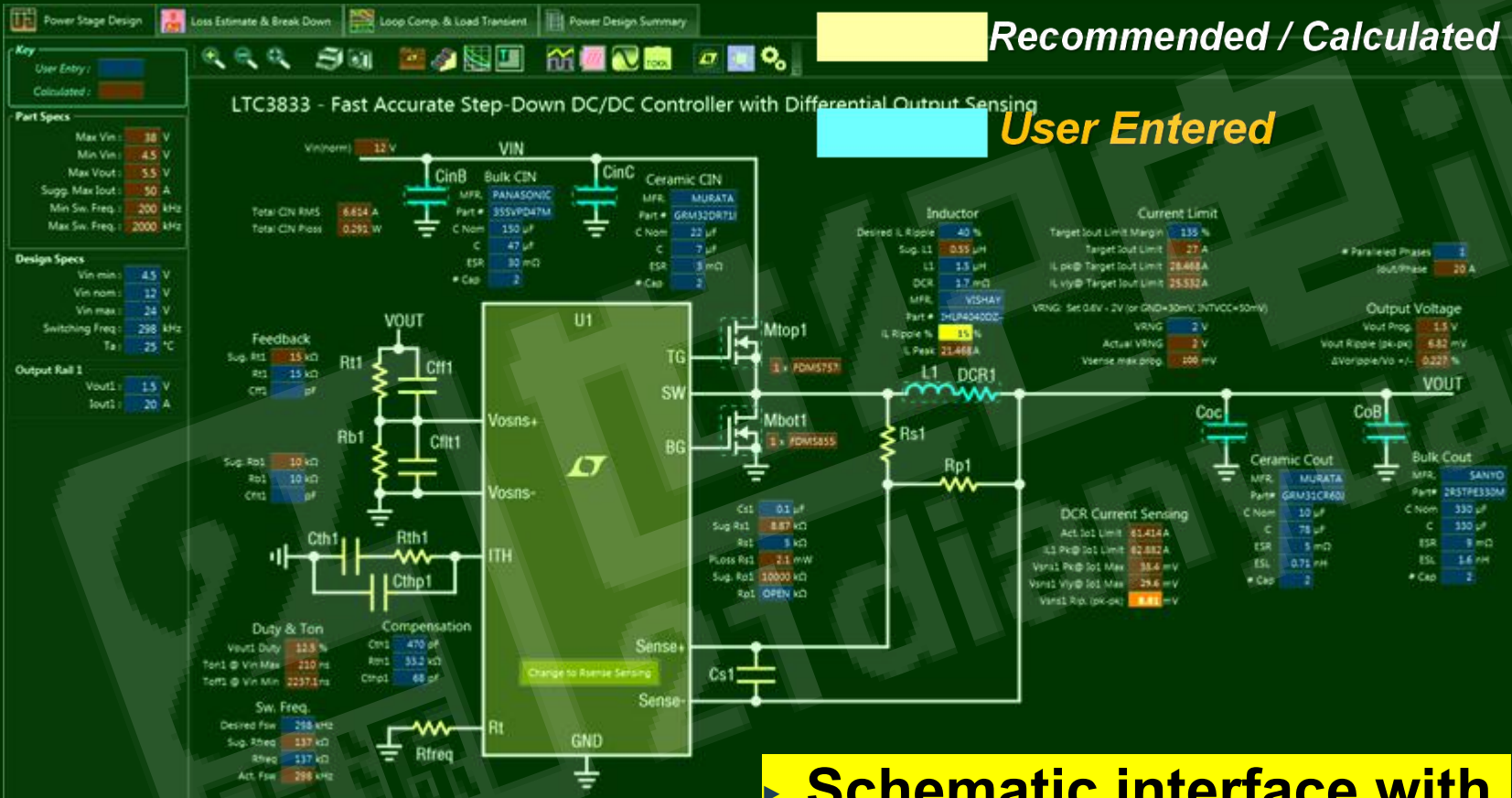

► Schematic interface with key component designs

Step 2 – Power Stage – ‘Smart’ Warnings

Strong warning

“Soft” warning

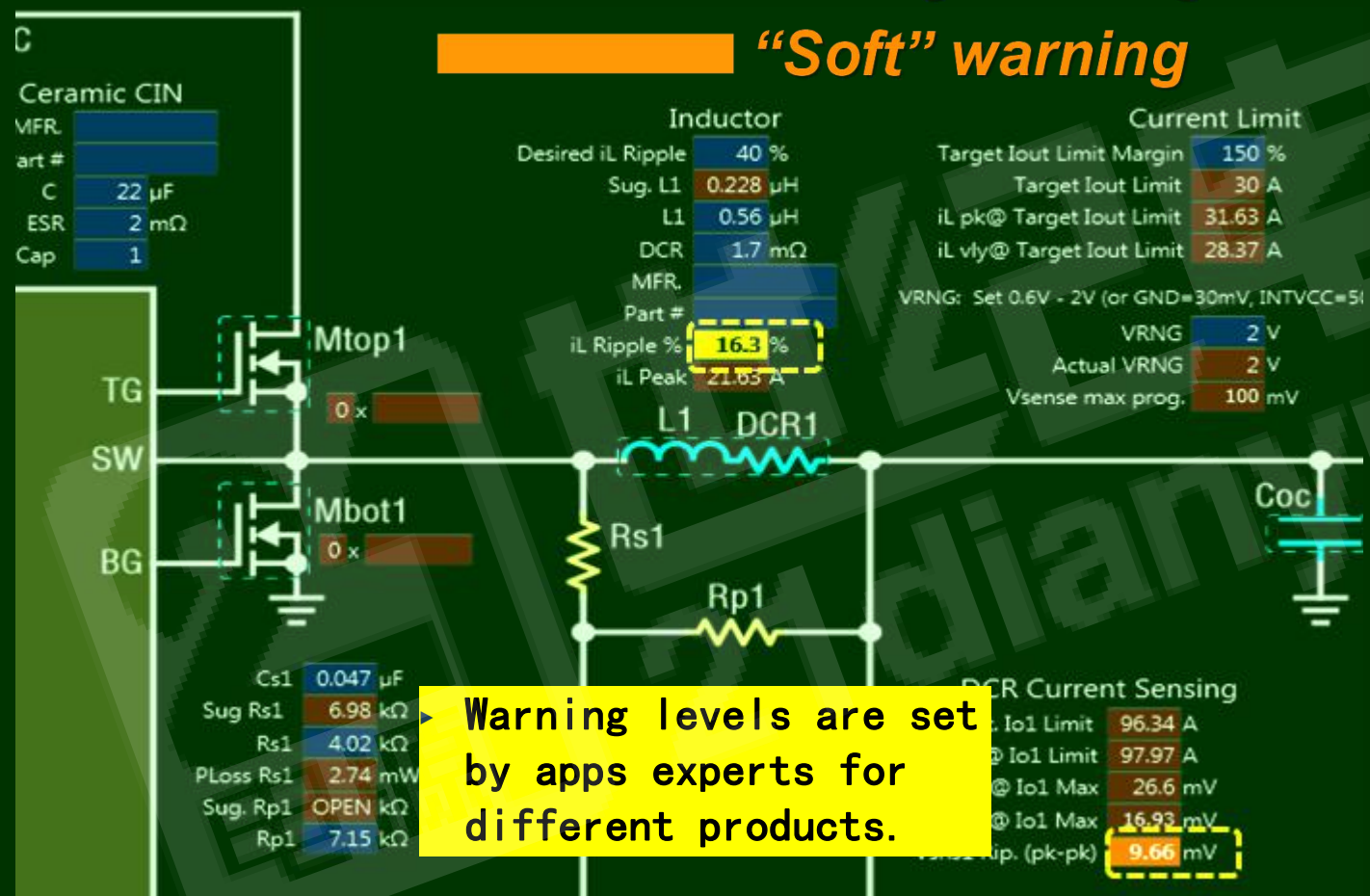

Warning levels are set by apps experts for different products.

Automatic warnings guide to proper values

Step 3 – Efficiency Optimization

Power Stage Design | Loss Estimate & Break Down | Loop Comp. & Load Transient | Power Design Summary

Output Rail #1

Design Specs

- Vin max: 13.2 V
- Vin nom: 12 V
- Vin min: 10.8 V
- Sw. Freq: 395 kHz
- Vout: 1 V
- Iout: 20 A

Inductor

- Inductor: MVR
- L: 0.25 uH
- DCR: 0.93 mΩ

Inductor Loss

- DCR Loss: 0.38 W
- Core Loss: W
- Total Loss: 0.38 W

Back

FET Vmiller

MOSFETs

Control MOSFET

- Vendor: Infineon
- Part: BSC0910NC
- Vds: 25 V
- Qg: 5.8 nC
- Rds(on): 4.53 mΩ
- Vdiode: 0.87 V
- PLoss: 0.48 W/Fet
- θj-c: °C/W

Sync MOSFET

- Vendor: NXP
- Part: PSMN093-5
- Vds: 30 V
- Qg: 59.4 nC
- Rds(on): 0.77 mΩ
- Vdiode: 0.78 V
- PLoss: 0.51 W/Fet
- θj-c: °C/W

Estimate

Freeze Plot

External Bias

EXTVCC: V

Rail Total Power Loss @ Full Load

- Pin: 21.74 W
- Pout: 20 W
- PLoss: 1.74 W
- η: 92.99 %

Cursor

- Iout: 17 A
- η: 92.1 %
- PLoss: 1.66 W

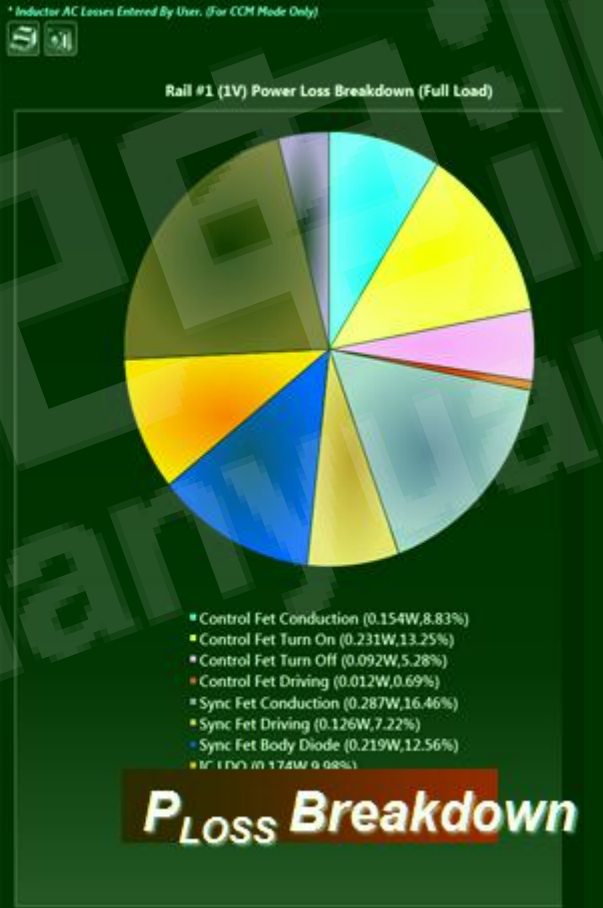
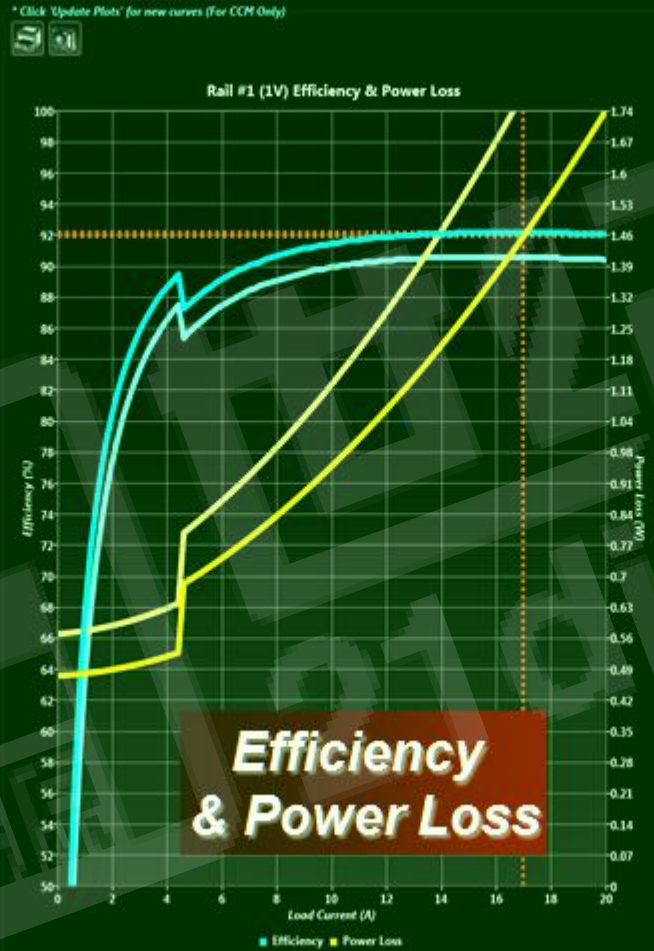

Real-time Estimations for Optimum η%

Step 4- Feedback Loop & Transient Designs

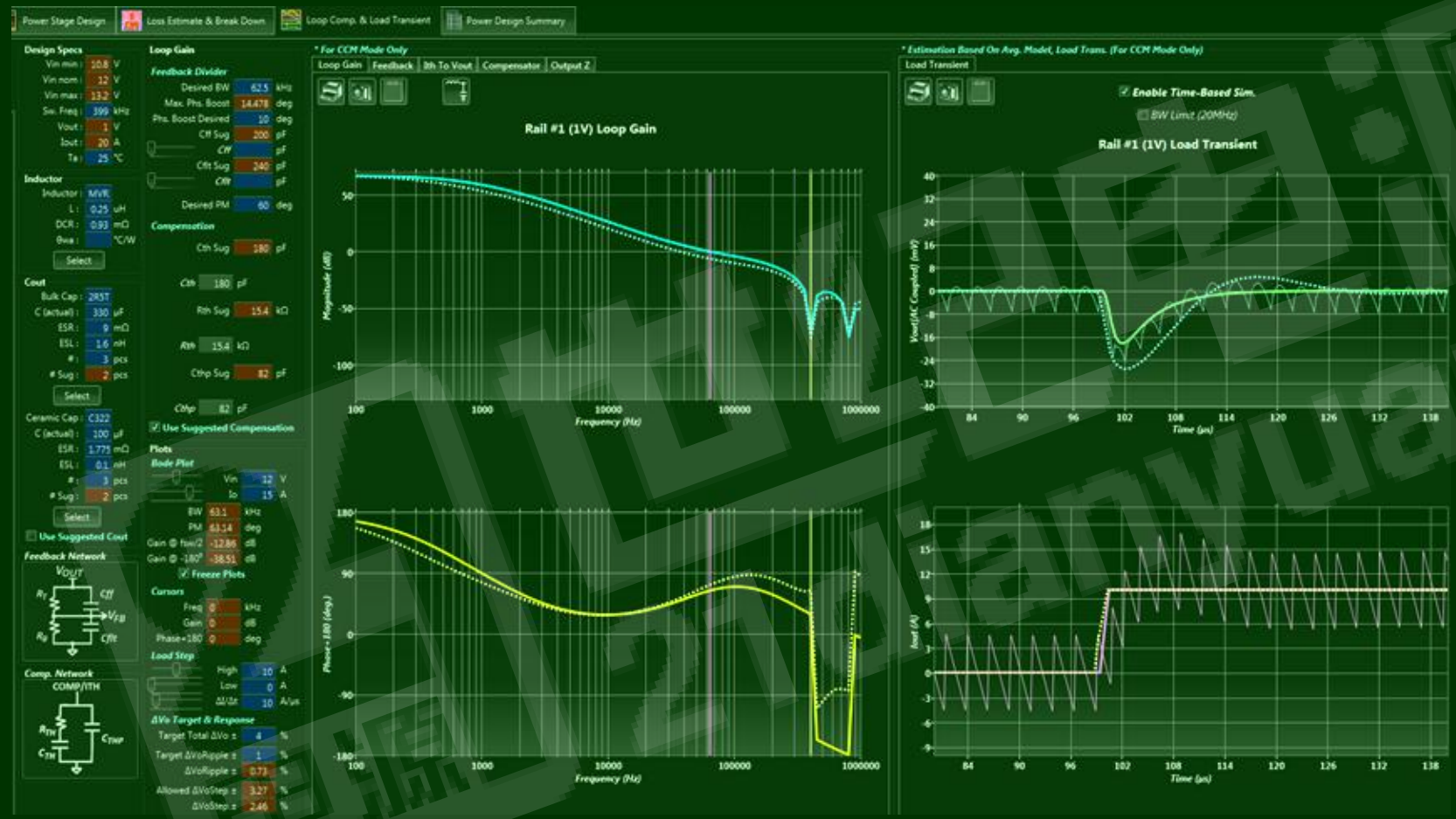

Real-time Loop & Transient Optimization

Step 5- Design Summary, BOM, Size

Loss Estimate & Break Down | Loop Comp. & Load Transient | **Power Design Summary**

Print Summary Report

Summary Report

LTC3833 Supply Design Summary

Project Info: Ref Design 12Vin to 1V/20A, 10/2014, H.Z.

Design Specifications

Steady State :

Rail #	Vin Min.	Vin Nom.	Vin Max.	Fsw	Vo	ΔVo rip. p-p	ΔVo rip.%	Io Max
1	10.8 V	12 V	13.2 V	399 kHz	1 V	7.82 mV	0.4 %	20 A

Performance Summary

Efficiency and Loop :

Rail #	Vo	Iomax	Eff.@Iomax	Ploss@Iomax	Loop BW	Loop PM	Step Low	Step High	Step Slew	ΔVo@Step	ΔVo@Step %
1	1 V	20 A	91.99 %	1.741 W	79.43 kHz	79.26 deg	0 A	10 A	10 A/μs	22.1 mV	+/-2.2 %

Recommendations and Warnings :

Message

Power Components

Power Components Bill Of Materials :

Export BOM

Ref. Des.	Value	Quantity	Description	Mfr. Name	Mfr. Part #	Pkg. (Imperial)	L(mm)	W(mm)	H(mm)	User Note
U1		1	IC	LINEAR TECH	LTC3833		4	3	0.8	
Lo1	0.25μH	1	IND	COILCRAFT	MVR1251T-251		11.5	9.75	5.1	
Cinb1	180μF	1	CAP	PANASONIC	16SVP180MX	F8	10.3	10.3	7.9	
Cinc1 Cinc2	47μF	2	CAP	MURATA	GRM32ER61C476KE15	1210	3.2	2.5	1.7	
Cob1 Cob2 Cob3	330μF	3	CAP	SANYO	2R5TPE330M9	D2E	7.3	4.3	1.8	
Coc1 Coc2	100μF	2	CAP	TDK	C3225X5R0107M	1210	3.2	2.5	1.7	
Qcontrol1	25V	1	FET	Infineon	BSC0910NDI_Q1		6.35	5.35	1.1	
Qsync1	30V	1	FET	NXP	PSMN0R9-30VLD		6	5	1.7	

BOM

Power Components Footprint :

# Components	12	
Max. Height	7.9	mm
Component Clearance (d)	1	mm
* Power Components Area (Excludes ICs)	541.5	mm ²
	0.839	in ²
* Power Components Area (Includes ICs)	561.5	mm ²
	0.87	in ²

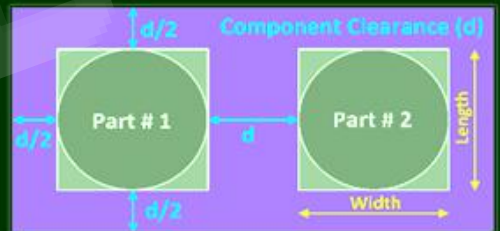

Solution Size



PCB Layout reference



LTpowerCAD II V2.5.4 - LTC3605 DC1215 Demo Board.rptc

Power Stage Design | Loss Estimate & Break Down | Loop Comp. & Load Transient | Power Design Summary

Key
User Entry :
Calculated :

Part Specs
Max Vin : 15 V
Min Vin : 4 V
Max Vout : 14 V
Supp. Max Iout : 5 A
Min Sw. Freq. : 800 kHz
Max Sw. Freq. : 4000 kHz

Design Specs
Vin min : 5 V
Vin nom : 12 V
Vin max : 14 V
Switching Freq. : 988 kHz
Ta : 25 °C

Output Rail 1
Vout1 : 3.31 V
Iout1 : 5 A

Linear Technology Demo Board
4-14Vin, 2.5V/3.3V/5V Select

LTC3605 - 5A, 15V Monolithic Buck Regulator

Project Name: Demo Board DC1215
Date: 9/2014

Layout Example

VIN, CIN, L1, VOUT, GND, COUT

Minimize the “hot-loop” of VIN pins, GND and CIN

LTPowerCAD DM Conducted EMI Filter Tool

▶ Open the EMI tool from the icon on schematic page.

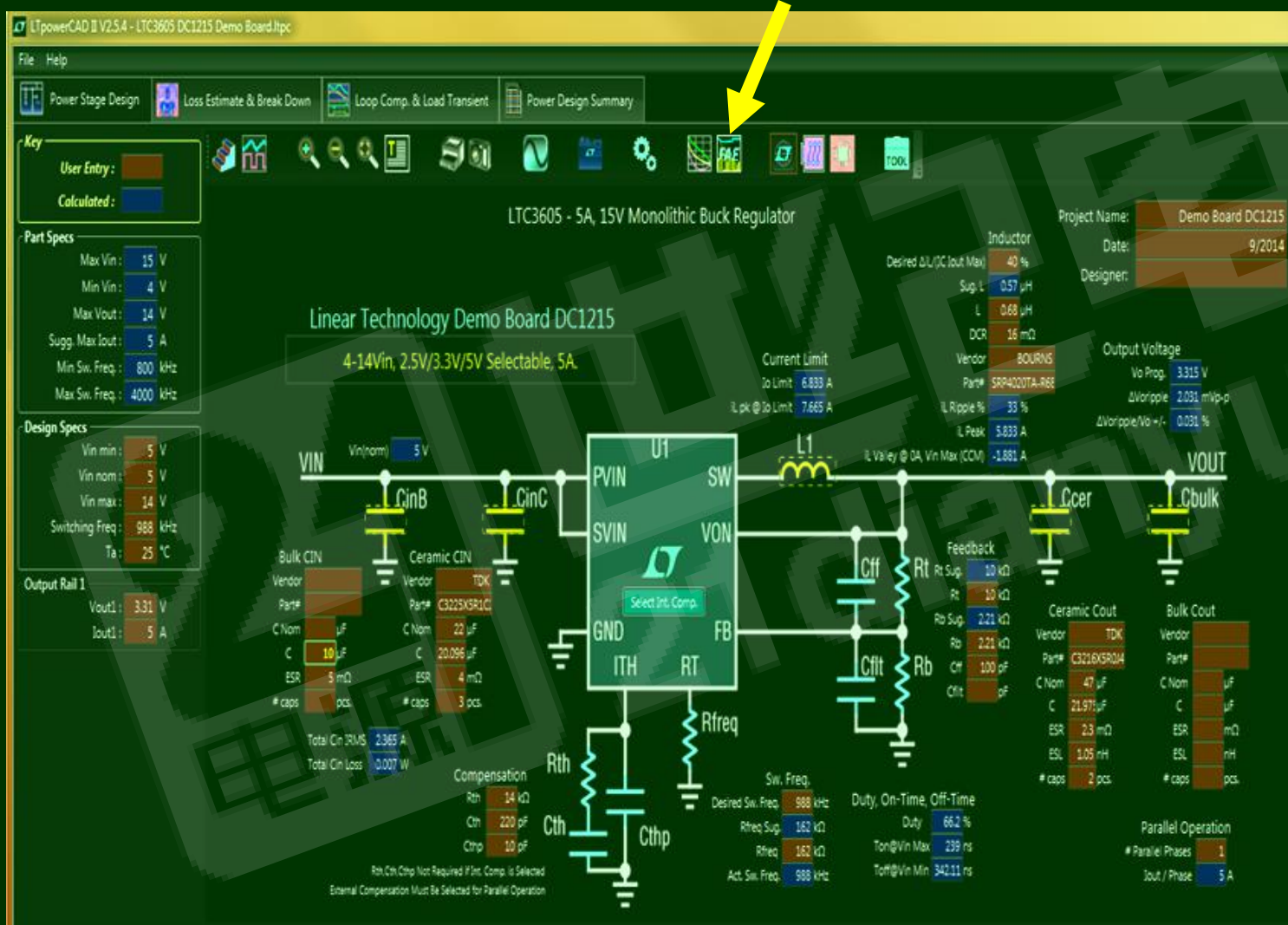

LTPowerCAD II V2.5.4 - LTC3605 DC1215 Demo Board.ltpc

File Help

Power Stage Design Loss Estimate & Break Down Loop Comp. & Load Transient Power Design Summary

Key: User Entry (Red), Calculated (Blue)

LTC3605 - 5A, 15V Monolithic Buck Regulator

Project Name: Demo Board DC1215
Date: 9/2014
Designer:

Linear Technology Demo Board DC1215
4-14Vin, 2.5V/3.3V/5V Selectable, 5A.

Part Specs

Max Vin:	15 V
Min Vin:	4 V
Max Vout:	14 V
Sugg. Max Iout:	5 A
Min Sw. Freq.:	800 kHz
Max Sw. Freq.:	4000 kHz

Design Specs

Vin min:	5 V
Vin nom:	5 V
Vin max:	14 V
Switching Freq.:	988 kHz
Ta:	25 °C

Output Rail 1

Vout1:	3.31 V
Iout1:	5 A

Inductor

Desired $\Delta I_{L(O)C} \text{out Max}$:	40 %
Sup L:	0.57 μH
L:	0.68 μH
DCR:	16 m Ω
Vendor:	BOURNS
Part#:	SRP4020TA-RE6
IL Ripple %:	33 %
IL Peak:	5.833 A
IL Valley @ 0A, Vin Max (CCM):	-1.881 A

Output Voltage

Vo Prog:	3.315 V
ΔV_{ripple} :	2.031 mVp-p
$\Delta V_{\text{ripple}}/V_o$:	0.031 %

Feedback

Rt Sup:	10 k Ω
Rt:	10 k Ω
Ro Sup:	2.21 k Ω
Ro:	2.21 k Ω
Cf:	100 pF
Cft:	pF

Ceramic Cout

Vendor:	TDK
Part#:	C3216XSR014
C Nom:	47 μF
C:	21.971 μF
ESR:	2.3 m Ω
ESL:	1.05 nH
# caps:	2 pcs.

Bulk Cout

Vendor:	
Part#:	
C Nom:	μF
C:	μF
ESR:	m Ω
ESL:	nH
# caps:	pcs.

Compensation

Rth:	14 k Ω
Cth:	220 pF
Cthp:	10 pF

Sw. Freq.

Desired Sw. Freq.:	988 kHz
Rfreq Sup:	162 k Ω
Rfreq:	162 k Ω
Act. Sw. Freq.:	988 kHz

Duty, On-Time, Off-Time

Duty:	66.2 %
Ton@Vin Max:	239 ns
Toff@Vin Min:	342.11 ns

Parallel Operation

# Parallel Phases:	1
Iout / Phase:	5 A

Other Parameters:

- Current Limit: Io Limit: 6.833 A, IL pk @ Io Limit: 7.665 A
- IL Valley @ 0A, Vin Max (CCM): -1.881 A
- Feedback: Rt Sup: 10 k Ω , Rt: 10 k Ω , Ro Sup: 2.21 k Ω , Ro: 2.21 k Ω , Cf: 100 pF, Cft: pF
- Compensation: Rth: 14 k Ω , Cth: 220 pF, Cthp: 10 pF
- Sw. Freq.: Desired Sw. Freq.: 988 kHz, Rfreq Sup: 162 k Ω , Rfreq: 162 k Ω , Act. Sw. Freq.: 988 kHz
- Duty, On-Time, Off-Time: Duty: 66.2 %, Ton@Vin Max: 239 ns, Toff@Vin Min: 342.11 ns
- Parallel Operation: # Parallel Phases: 1, Iout / Phase: 5 A

DM EMI Filter Design - Integrated in LTpowerCAD

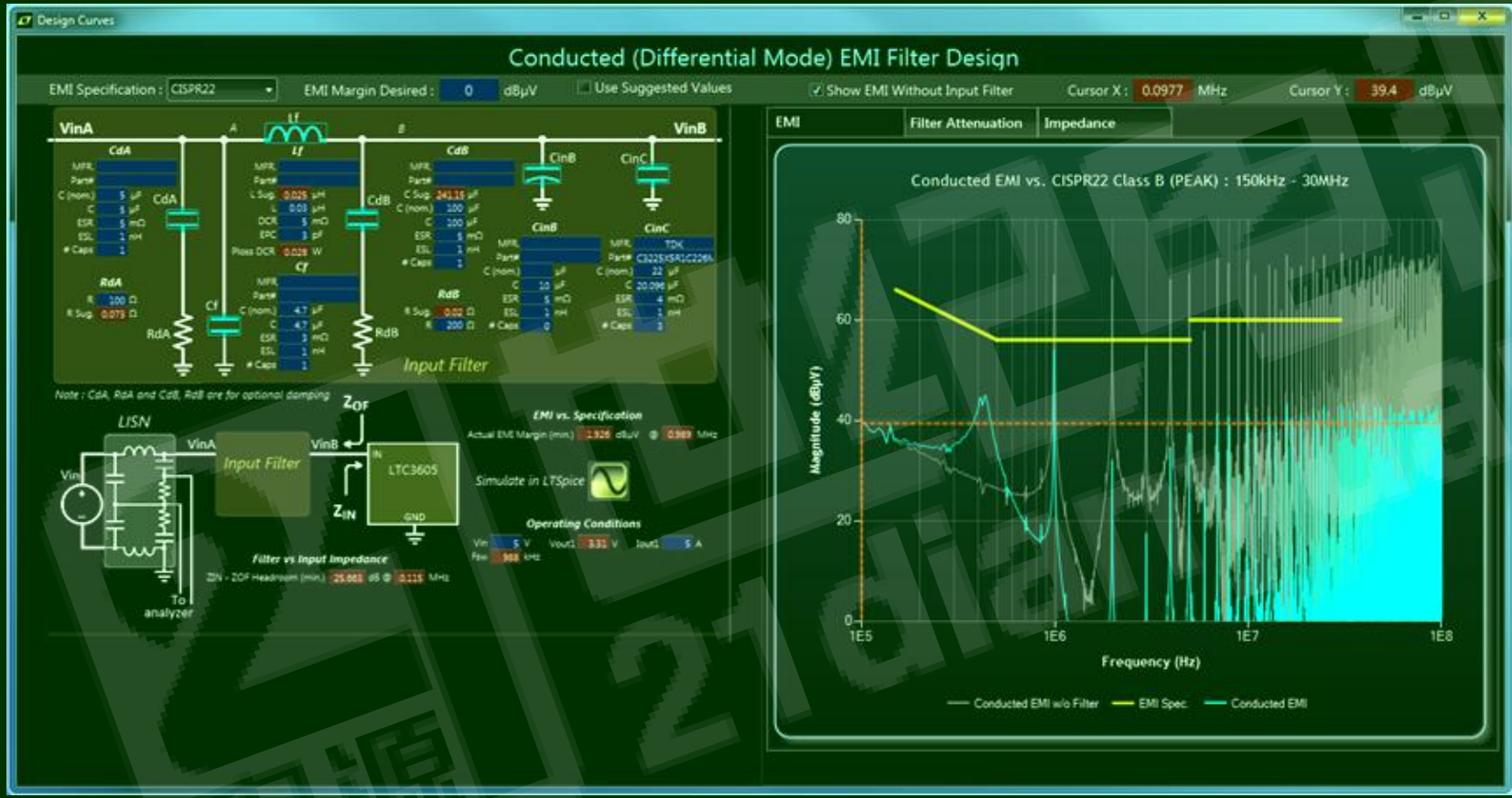

▶ First few orders of harmonics determine the filter size.



DM EMI Noise - Estimated vs. Measured Data

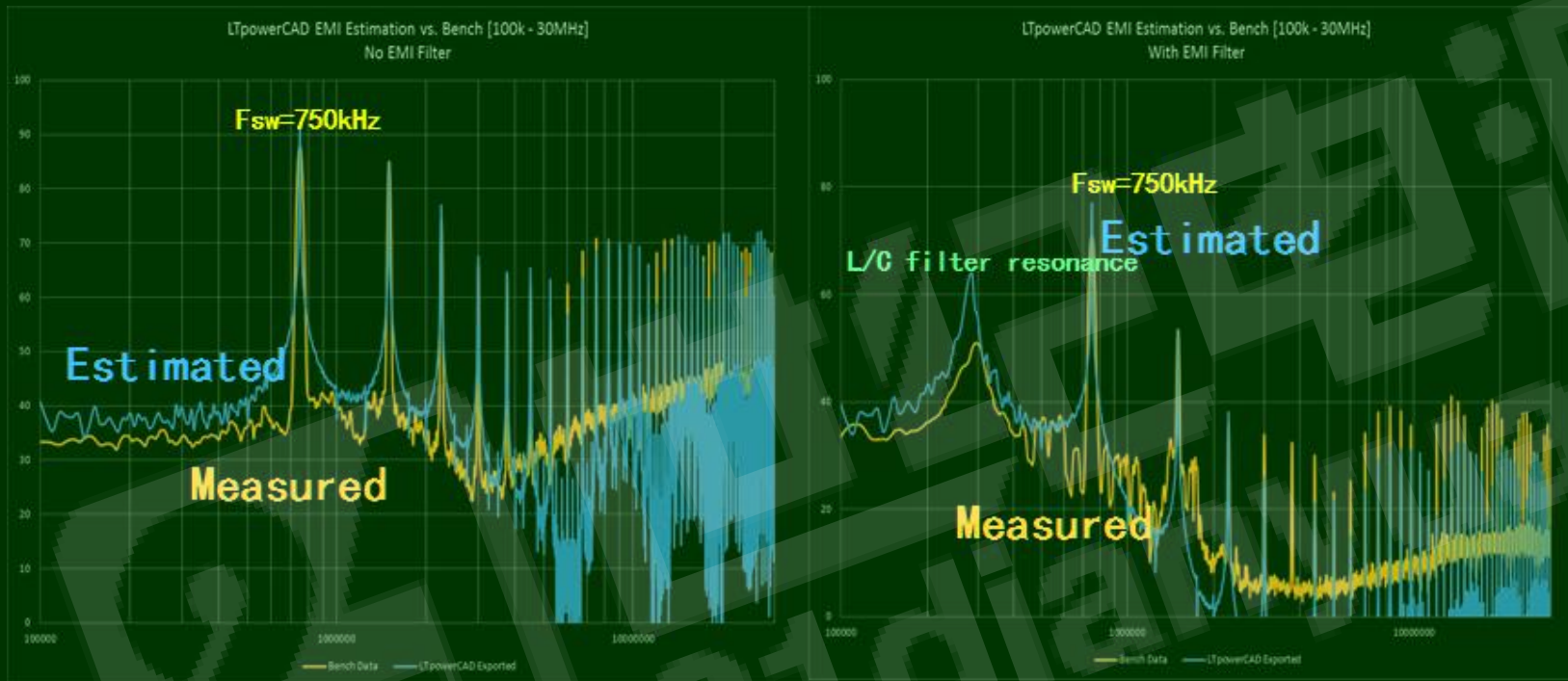

- ▶ LTC3851A single phase buck demo board.
(12V_{in} to 1.5V_o/15A, 750kHz).
- ▶ **Good matching of peak values.**

LT power CAD 下载 - 免费!!!



- ▶ LTpowerCAD power supply design tool
- ▶ Free download @ www.analog.com/LTpowerCAD
- ▶ Runs on Windows PC.

Application Example

How to get balance with 3 Key Metrics



21dianyuan.com

Typical signal sampling system power design

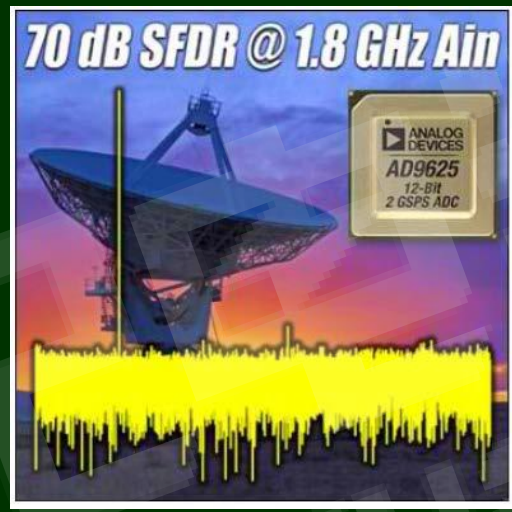
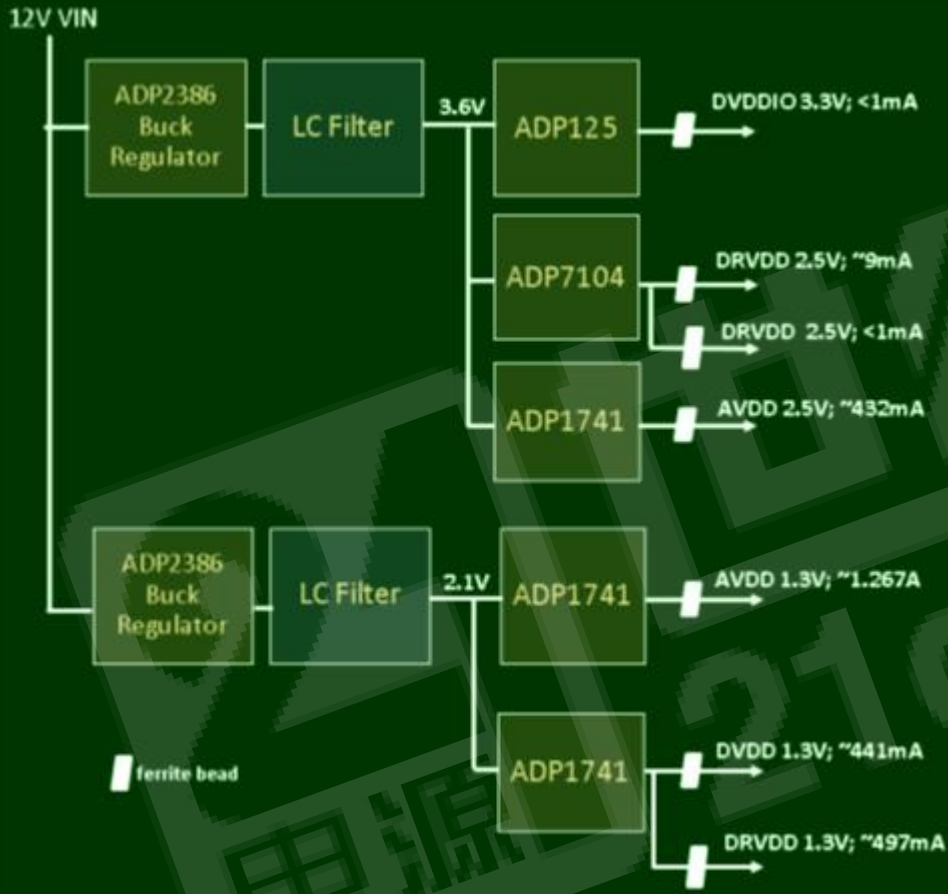

- ▶ Good Performance
- ▶ 48% efficiency
- ▶ Thermal issue
- ▶ Big power size

Package technology improves performance



LT8640
QFN

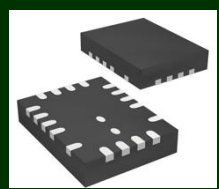

LT8640S
(BT laminate LGA)

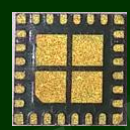

LTM8053
6x9 BGA

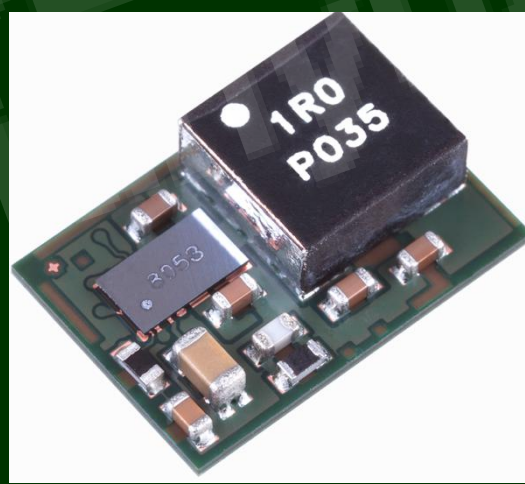
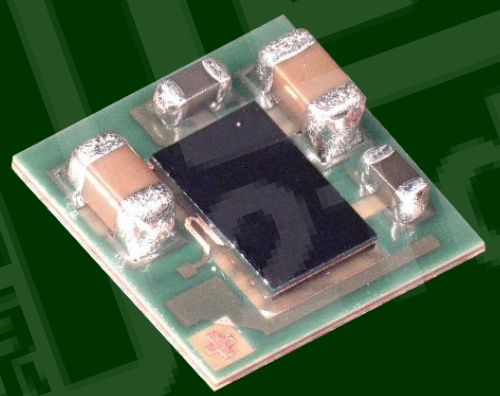
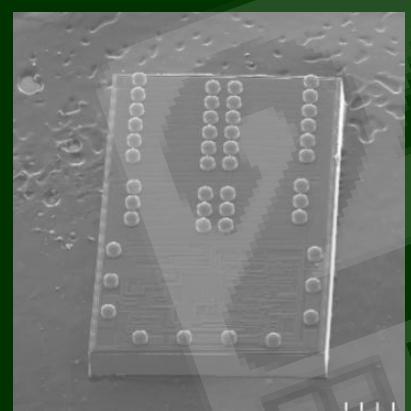

40Vin Silent Switcher μ Module Regulators

	LTM8074	LTM8063	LTM8065	LTM8053
Silent Switcher		Yes	Yes	Yes
CISPR22 Class B		Yes	Yes	Yes
Vin Range	3.2V to 40V	3.2V to 40V	3.4V to 40V	3.4V to 40V
Vout Range	0.8V to 12V	0.8V to 15V	0.97V to 15V	0.97V to 15V
Iout	1.2A (Continuous) 1.75A (Peak)	2A (Continuous) 2.5A (Peak)	2.5A (Continuous) 3.5A (Peak)	3.5A (Continuous) 6A (Peak)
Switching Frequency		200kHz to 2.2MHz	200kHz to 3MHz	200kHz to 3MHz
Package Size (mm)	4 x 4 x 2.22	4 x 6.25 x 2.22	6.25 x 6.25 x 2.32	6.25 x 9 x 3.32
Package Type	BGA	BGA	BGA	BGA

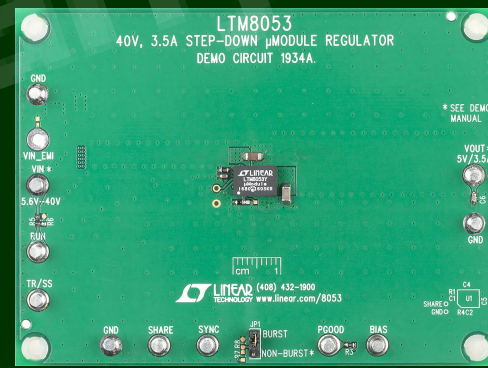
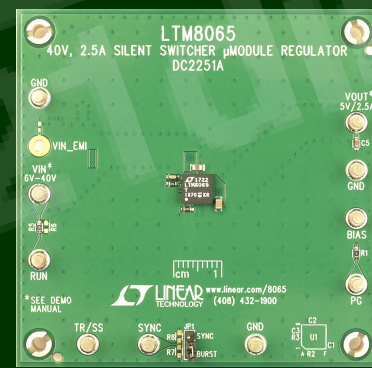
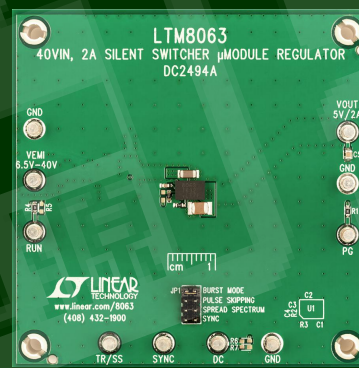
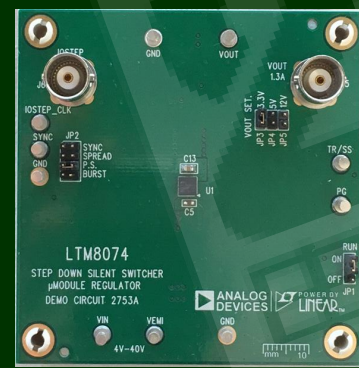



New Power Solution

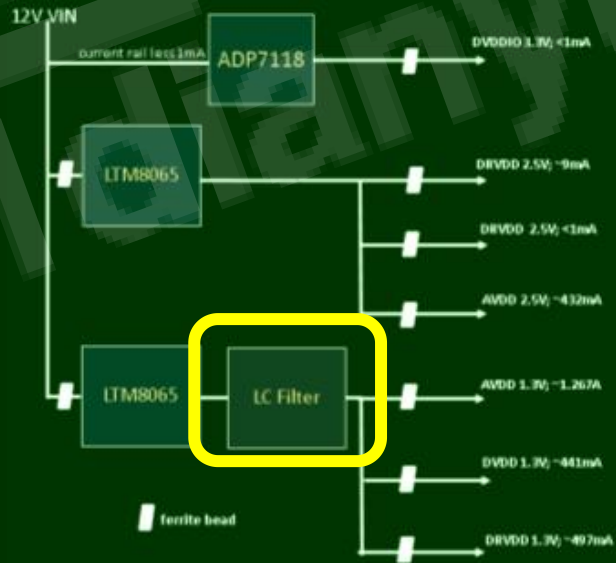
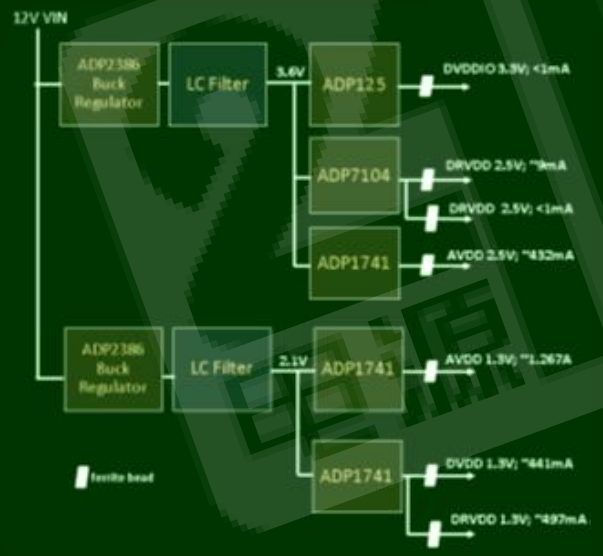
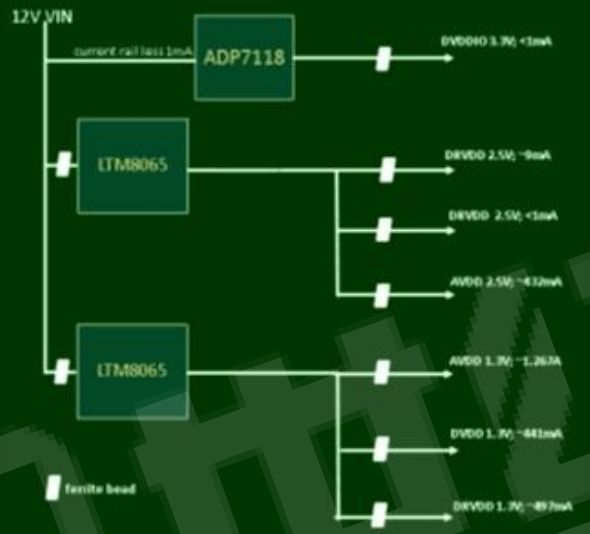



Good Power solution and performance



AD9625-2.6 GHz Dynamic Performance

Input Frequency (MHz)	SNRFS (db)			SFDR (dbc)		
	Baseline Power Supply	LTM8065 Version1	LTM8065 Version 2	Baseline Power Supply	LTM8065 Version1	LTM8065 Version 2
729	57.01	57.03	57.01	79.87	79.72	80.11
1349	56.53	56.49	56.54	78.41	80.06	80.77

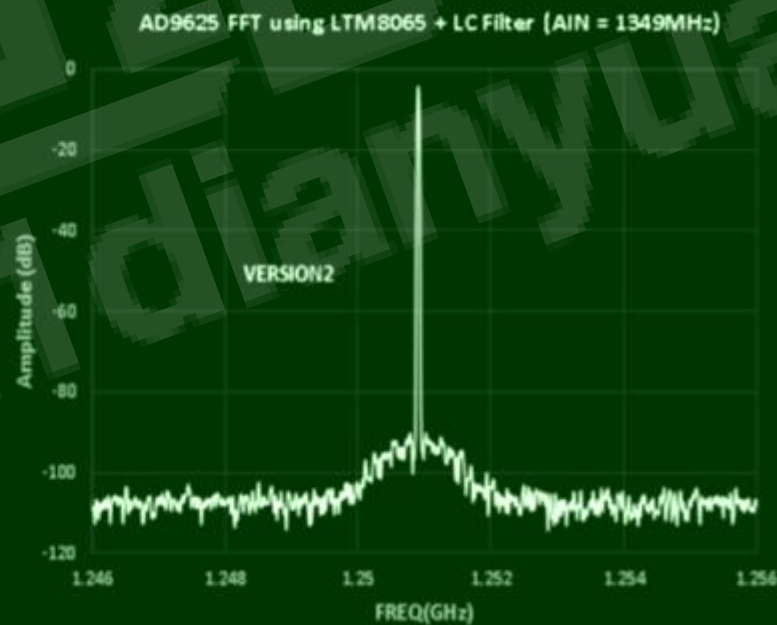
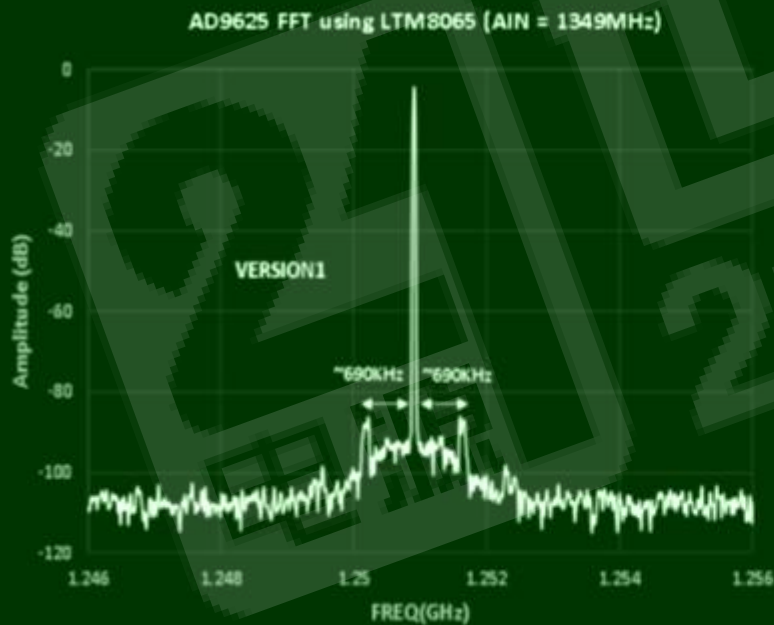

Good Power solution and performance



Baseline Power Supply		Voltage (V)	Current (A)	Power (W)
PIN		11.729	0.676	7.929
P O U T	AVDD_1.3V	1.268	1.222	1.549
	DRVDD_1.3V	1.301	0.521	0.678
	DVDD_1.3V	1.305	0.406	0.530
	AVDD_2.5V	2.589	0.408	1.056
	DRVDD_2.5V	2.590	0.0047	0.012
	DVDD_2.5V	2.590	0.0001	0.0003
	DVDDIO_3.3V	3.301	0.0004	0.0013
POUT TOTAL:			3.827	
Efficiency (%):			48.26	

LTM8065 Version 2		Voltage (V)	Current (A)	Power (W)
PIN		11.885	0.442	5.256
P O U T	AVDD_1.3V	1.303	1.308	1.704324
	DRVDD_1.3V	1.302	0.531	0.691
	DVDD_1.3V	1.305	0.459	0.599
	AVDD_2.5V	2.486	0.440	1.094
	DRVDD_2.5V	2.494	0.005	0.012
	DVDD_2.5V	2.496	0.0001	0.0002
	DVDDIO_3.3V	3.301	0.0004	0.0013
POUT TOTAL:			4.102	
Efficiency (%):			78.05	

+30%

Silent Switcher uModule – Save PCB size

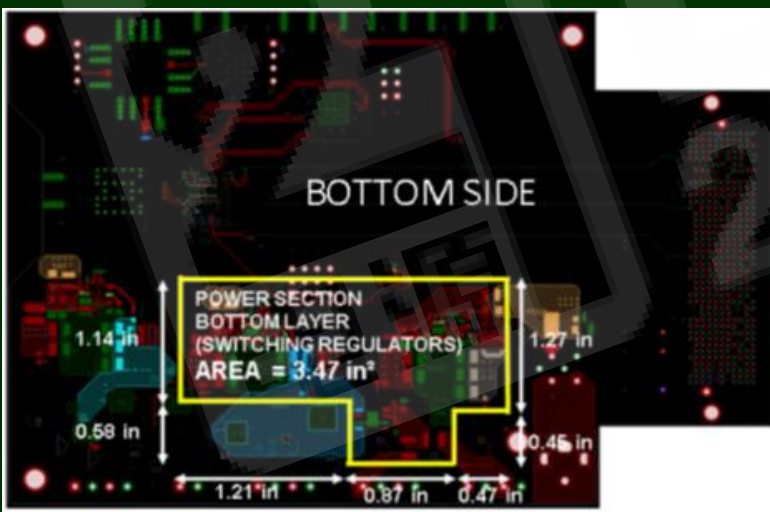

PCB Size
6.32 in² VS 1.72 in²
Save 73% space



• The End!



21世纪电源网
21dianyuan.com